



# AGILENT TURBO PUMPS

2-5	Introduction
6-7	Molecular Drag Technology
8-9	Agilent Floating Suspension
10-11	Turbo Pump Technology
12-13	Turbo Pump Technology for Instrumentation
14-17	Typical Applications
18-55	Turbo Pump Models
56	Accessories
57-59	Technical Notes
60-62	Service and Support Plans



**Agilent Technologies**

## The Agilent Advantage

A complete family of Turbo Pumps including the innovative break-through TwisTorr FS pumps.

- Agilent turbo pumps are designed for reliability and optimum performance in real world applications to meet highest quality standard
- Our pump range also includes integrated pumping systems, multiflow pump solutions for scientific instruments, and dedicated solutions for vibration-sensitive applications in nanotechnologies

**2013** • Agilent introduces the new TwisTorr 304 FS, with Agilent Floating Suspension



**2010** • Agilent Technologies presents the new TwisTorr molecular drag technology based on its well-known hybrid Turbo Molecular Pump design, introducing a spiral drag section that achieves unmatched performance in both pumping speed and compression ratio in the most compact space available. New state-of-the-art electronics complete this industry leading Turbo Molecular Pump innovation



**2004** • Varian develops a dedicated range of SEM products that meets the most stringent requirements of the industry



**2003** • With the Turbo-V 2K-G Varian, now Agilent, introduces a fully integrated Turbo system



**1996** • Introduction by Varian of microprocessor-based on-board controller units: Navigator line, for computer driven plug-and-pump operation



**1991** • Varian introduces a new hybrid type Turbo Molecular Pump: one monolithic rotor provides both high speed (Turbo stages) and high foreline tolerance (MacroTorr stages)  
• Use of ceramic ball bearings with life-time lubrication using a proprietary dry solid lubricant



**1986** • Varian starts an innovative pilot project to develop turbomolecular pump technology in collaboration with Italian hi-tech company Elettrorava



## Turbopump Operating Principles

Turbomolecular pumps consist of a series of bladed impellers rotating at high speed and fixed bladed stators. These impellers and stators are alternately spaced and are inclined in opposite directions.

The pumping action is based on momentum transfer from the fast moving impeller surface to the gas molecules. The speed of the moving surface must be as high as possible to achieve optimum pumping efficiency in terms of pumping speed and compression ratio. When this mechanism takes place several times in a pump a pumping action is created. The sequence of alternating rotors and stators typical of a conventional

turbomolecular pump develops the compression ratio. Turbomolecular drag pumps operate according to the same principle, but with a different geometry in the pumping stages. Gas molecules collide against a fast moving wall and are dragged into a channel toward the high pressure region. Conventional turbomolecular pumps have high pumping speed but low compression ratio at foreline pressures higher than  $10^{-1}$  mbar. Molecular drag pumps have low pumping speed but high compression ratios up to foreline pressures of more than 20 mbar. When the two types of stages are combined together in one pump, extended operational pressure ranges can be achieved.

# TURBO PUMPS



## Turbomolecular Pump Parameters and Definitions

### Throughput

“Throughput” is the flow rate of pumped gas through the turbomolecular pump (and foreline pump).

Throughput (Q) is measured in mbar l/s 1/60 standard cm<sup>3</sup>/min. The maximum throughput a pumping system can handle is, in general, dependent upon the size of its foreline pump rather than the turbomolecular pump.

### Pumping Speed

“Pumping speed” (S) (volumetric flow rate) of a turbomolecular pump is the ratio between throughput and inlet pressure (foreline pump size must be the recommended one as a minimum).

$$S = Q / p$$

The pumping speed of a turbomolecular pump is constant over a wide pressure range and depends upon geometric factors such as diameter and rotational speed. For most turbomolecular pumps, pumping speed is nearly independent from gas species (molecular weight).

### Compression Ratio

“Compression Ratio” is the ratio between foreline (partial) pressure and inlet (partial) pressure for a given process gas, measured in “zero flow” conditions (performed by injecting the process gas in the pump foreline while the high vacuum port is blanked off).

Compression ratio is generally indicated with the letter “K”. In technical specifications of turbomolecular pumps, it is the maximum attainable value of K (at low foreline pressure). Compression ratio is, in fact, a function of the foreline pressure as shown in Figure 1.

Compression ratio decays at high pressure depending on turbomolecular pump configuration (the number of molecular stages) and/or power limitations that slow down the rotor (gas friction increases with pressure).





# INTRODUCTION

The maximum compression ratio is strongly influenced by gas species: it is an exponential function of the molecular weight of the pumped gas (compression ratio is considerably lower for light gases).

## Pumping Speed and Pressure Ratio

The pressure ratio between foreline and inlet pressures in each operational situation is indicated by "Rp". This is, in general, equal to pumping speed ratio

$$R_p = P_{foreline} / P_{inlet} = S_{eff} / S_{foreline}$$

where  $S_{eff}$  is the effective pumping speed, and  $S_{foreline}$  is the pumping speed of the foreline pump.

In fact

$$Q = S_{eff} P_{inlet} = S_{foreline} P_{foreline}$$

therefore

$$S_{eff} / S_{foreline} = P_{foreline} / P_{inlet}$$

The pumping speed of a turbomolecular pump is minimally affected by pressure ratio (and foreline pump size) in most common operational conditions (when pressure ratio is much smaller than K).

Generally, however, the effective pumping speed " $S_{eff}$ " is a linear function of the pressure ratio " $R_p$ " as shown in Figure 2 (and therefore is also dependent upon the size of the backing pump).

$S_{eff}$  reaches its maximum value "S" (nominal pumping speed) when " $R_p$ " equals unity, and it is zero when the pressure ratio  $R_p$  has reached its maximum value "K".

This linear dependence can be expressed by the following relationship:

$$S_{eff} = S / (1 - 1 / K + S / S_{foreline}K) \tag{1}$$

As it can be seen:  
when

$$K \gg S / S_{foreline}$$

and

$$K \gg 1$$

then

$$S_{eff} \approx S$$

when

$$K \approx 1$$

then

$$S_{eff} = S_{foreline}$$

The above formula (1) must be used to evaluate pumping speed when operating at high pressure, especially with light gases (low K).

## Base Pressure

The base pressure of a turbomolecular pump is the equilibrium pressure between outgassing of pump surfaces exposed to high vacuum, including test dome, and the pumping speed of the pump.

$$P_{base} = Q_{outgas} / S_{eff}$$

In the case of ultimate operational pressure, as specified by norms, the pressure is measured after 48 hours bakeout of pump and dome (provided with metal gasket); therefore the prevailing outgassing product is H2 and equilibrium is reached with hydrogen pumping speed.

$$P_{base} = Q_{H2} / S_{effH2}$$

When foreline pumps with relatively high base pressures are used, base pressure is sometimes limited by the compression ratio for H2O (or N2).

$$P_{base} = P_{forelineH2O} / K_{H2O}$$

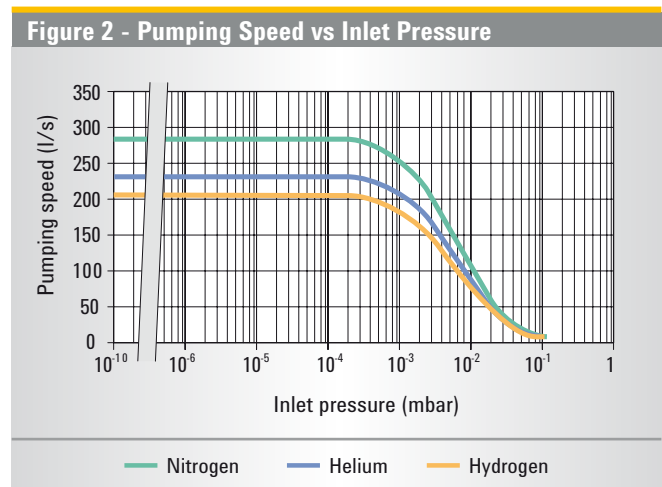
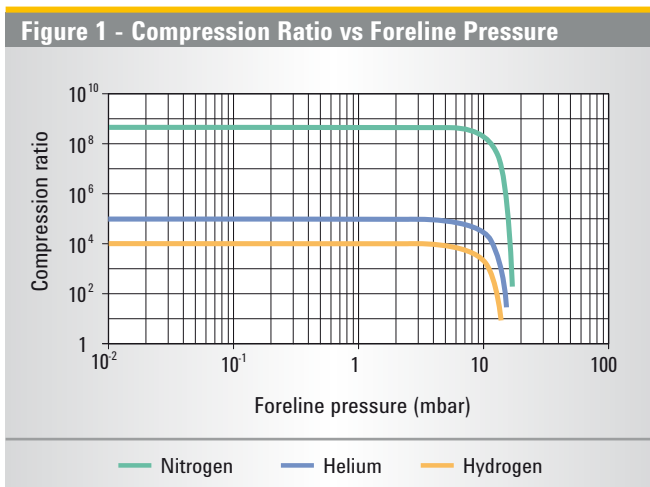



## Pump Selection

### How to Select a Turbo-V Pump

The right choice of a turbomolecular pump depends on the application; as a general rule we can reduce the choice to two types of use:

UHV (no gas flow) operations and Process Gas flow operations.

#### – UHV (no gas flow) operations.

The former case includes most cases in which the turbomolecular pump is employed to create vacuum in systems where the gas load is mainly produced by outgassing. In this application the choice is typically based on the desired base pressure within a desired time as a function of the foreseen outgassing rate, i.e.

$$S_{\text{eff}} = Q / p$$

where:

- $p$  is the desired base pressure (mbar)
- $Q$  is the total outgassing rate at the desired time (mbar l/s)
- $S_{\text{eff}}$  is the effective pumping speed

#### – Process Gas flow operations.

The second case relates to all operations where process gases must be used. The main parameters are therefore the desired operation pressure and the process gas flow

$$S_{\text{eff}} = Q' / p'$$

where  $Q'$  is the total gas flow and  $p'$  is the operating pressure.

### How to Select the Backing Pump of a Turbomolecular Pump

The selection of a backing pump should be based analyzing two requirements of the vacuum system:

- a. the roughing time
  - b. the minimum recommended backing pump of the turbo
- a. Roughing: once the desired roughing time is established, the size of the forepump can be determined through the following formula:

$$S_{\text{foreline}} = (V / t) \ln (p_0 / p_1)$$

where

- $S_{\text{foreline}}$  is the pumping speed of the roughing pump (l/min)
- $V$  is the volume of the chamber to be evacuated (l)
- $t$  is the desired roughing time (min)
- $p_0$  is the starting pressure (mbar)
- $p_1$  is the end pressure (mbar)

When using a foreline pump much larger than the recommended size, a by-pass line might be necessary to achieve calculated roughing time.

- b. Backing: the backing pump must be big enough to achieve an effective pumping speed as close as possible to the nominal speed.

$$p_{\text{foreline}} = Q / S_{\text{foreline}}$$

where

- $S_{\text{foreline}}$  is the pumping speed of the foreline pump
- $Q$  is the gas load
- $p$  is the operating foreline pressure

It should be noted that  $Q$  is the total gas load on the pump and includes process gases and turbo purge gases when used.

The size of the backing pump can be calculated according to the following rule:

$$S_{\text{foreline}} \geq 20S / K$$

where

- $S$  is the pumping speed of the turbopump
- $S_{\text{foreline}}$  is the pumping speed of the backing pump
- $K$  is the maximum compression ratio of the turbopump for a given gas (i.e.: process gas) at the operating foreline pressure.

The pumping speed of the backing pump should be the higher of the two values calculated as above (roughing and backing).

Finally, it is possible to use a dry pump (scroll or diaphragm) for hydrocarbon-free operation when pumps of the MacroTorr type are used.

# MOLECULAR-DRAG TECHNOLOGY

Drag Technology allows higher foreline pressure, higher efficiency and smaller backing pump in a very compact design. Agilent solutions are designed using state of the art, proprietary numerical modeling. We offer optimized solutions for:

- Pumps with high compression ratio for UHV applications requiring lowest base pressure
- Pumps with high pressure differential for high throughput
- Pumps with high discharge pressure allowing downsizing of the complete vacuum system

Agilent developed two innovative molecular drag stages technological platforms: TwisTorr and MacroTorr.

## AGILENT TWISTORR TECHNOLOGY\*

- Pumping effect is created by a spinning rotor disk which transfers momentum to gas molecules
- Gas molecules are forced to follow spiral groove design on the stator. The specific design of the channel ensures constant local pumping speed and avoids reverse pressure gradients, minimizing power consumption

(\* US Patents applications 12/343961 and 12/343980, 24 Dec. 2008.

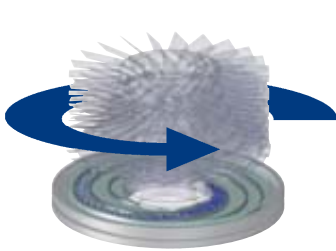

### Centripetal pumping action

Lower surface area of rotating disk transfers momentum to gas molecules  
Spiral groove design on the upper section of the TwisTorr stator causes a **centripetal** pumping action (**Blue** colored gas flow)



### Centrifugal pumping action

Upper surface area of rotating disk transfers momentum to gas molecules  
Spiral groove design on the lower section of the TwisTorr stator causes a **centrifugal** pumping action (**Red** colored gas flow)

## Loading Edge Performance

- The TwisTorr Pumps offer the highest pumping speed in their category for all gases
- The state of the art TwisTorr technology also achieves the highest compression ratios for light gases in a commercially available Turbo Molecular Pump
- Besides offering the highest performance, average power consumption results particularly low

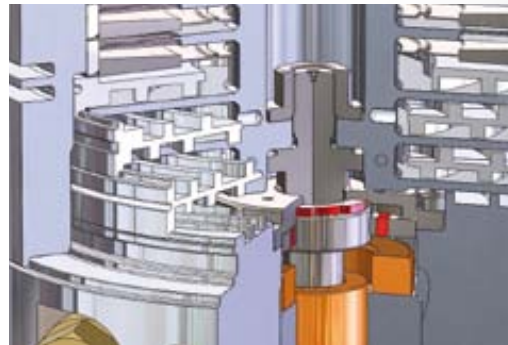

Gas flow in centripetal and centrifugal direction through TwisTorr channels

## Space Saving Design

- Our rotor is based on the proven Agilent monolithic rotor design which positions the TwisTorr Stator between two smooth spinning disks and therefore exploits the pumping action by both disk surfaces in series
- The double-sided spiral groove design on the TwisTorr stators combines centripetal and centrifugal pumping action in series, greatly compacting the size of the drag section

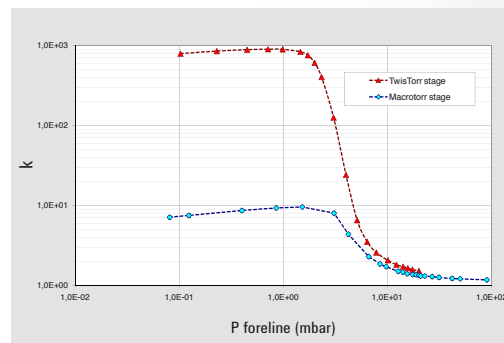

## Compression Ratio

- Compression ratio for N<sub>2</sub> of a single TwisTorr stage can increase up to a factor of 100 with respect to a conventional stage of the same space and rotor speed, providing exceptional foreline tolerance and pumping speed

# TURBO PUMPS

## TwisTorr Technology in Agilent Turbo Pumps



**Turbo section:** turbo stators



**Turbo section:** aluminum rotor with turbo stages designed to optimize pumping speed for light gases



**Drag section:** New TwisTorr technology TwisTorr drag stages (spiral channels) designed for high compression ratio performances

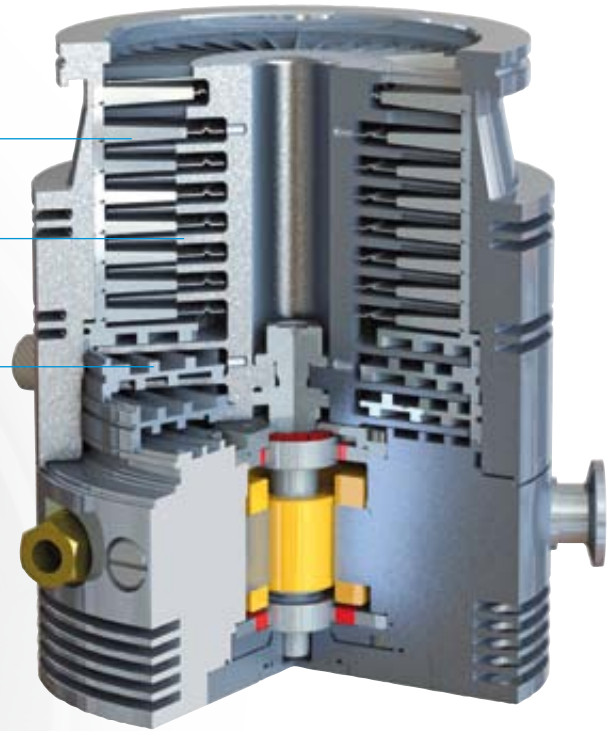

## AGILENT MACROTORR TECHNOLOGY

### The MacroTorr Concept

Agilent patented MacroTorr design is based on the idea of replacing (rather than adding) molecular impeller disks to some turbo bladed stages.

The molecular impellers consist of a disk rotating in a channel in which the inlet and outlet are divided by a wall.

The cross section of the channels decreases from the top to the bottom of the pump (from high vacuum to low vacuum or from the low pressure to the high pressure zone).

Gas molecules gain momentum after each collision with the moving surface of the impeller. The gas is then forced to pass through a hole to the next stage due to the wall.

The result is a product that, with the same dimensions as a conventional turbopump, provides: high compression ratios for light gases and high compression ratios at high foreline pressure. This allows the use of a very small mechanical pump while maintaining a low inlet pressure, or the use of a dry pump, for an oil free environment, and high throughput capacity at inlet pressures greater than  $10^{-3}$  mbar.

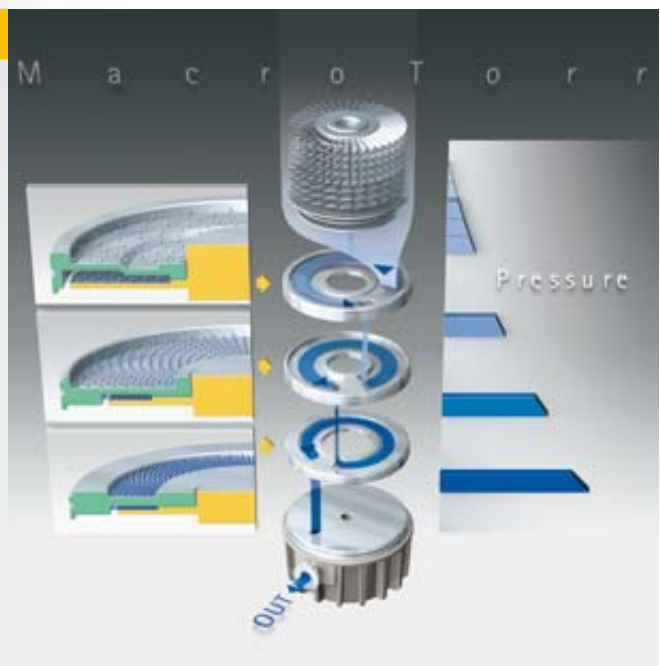



# FLOATING SUSPENSION

## AGILENT FLOATING SUSPENSION

The Turbomolecular pumps' rotor rotates at very high speed to provide the necessary pumping effect. In that operative mode there are several crucial parameters to be rigorously controlled and managed:

- radial positioning
- axial alignment
- bearings axial pre-load

**Agilent designed a patented innovative suspension technology that gives to Agilent Turbo Pumps the best dynamic behaviour, resulting in low noise, low vibration and longer bearings' life.**

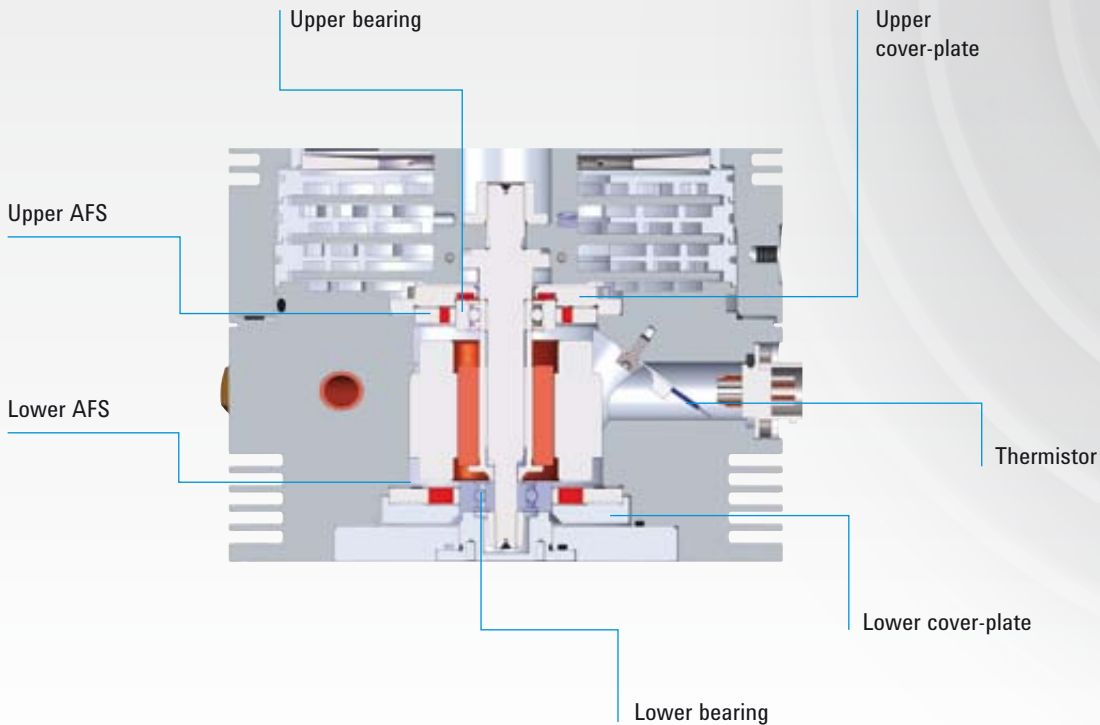

## Mechanical Design

SST shaft screwed on Al rotor to provide rotor stability (bending effect, behaviour under external shock loads)

Agilent Floating Suspensions (AFS)

- AFS geometrical precision to guarantee bearing alignment
- Designed radial stiffness to optimize rotor dynamic behaviour and acoustic noise
- Lower AFS acts as an axial spring to provide bearing's constant pre-load and rotor axial positioning
- Thermal stability
- Vibration stability over time



# TURBO PUMPS

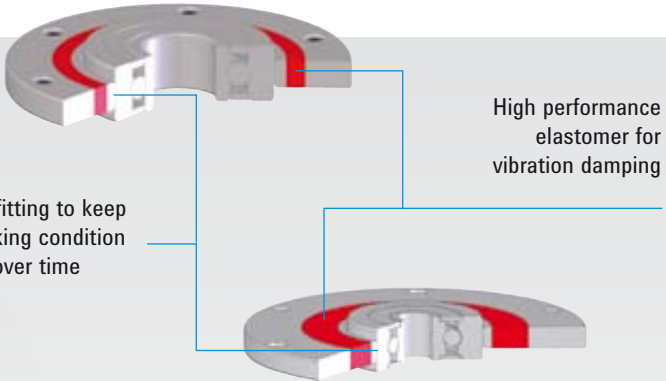

Radial press fitting to keep the best working condition for bearings over time

High performance elastomer for vibration damping

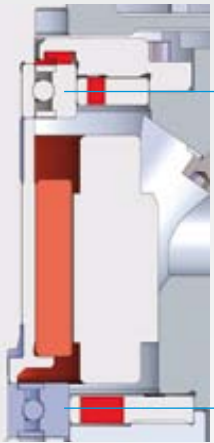

- AFS geometrical precision guarantees perfect bearings alignment
- Designed radial and axial stiffness, optimized rotor dynamic behaviour and acoustic noise
- Lower AFS acts as an axial spring providing bearing's preload and rotor axial positioning
- Thermal stability



Lower AFS

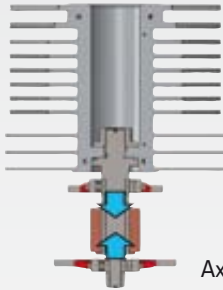
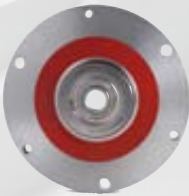

Axial bearings pre-load

Floating rotor to improve vibration damping and control

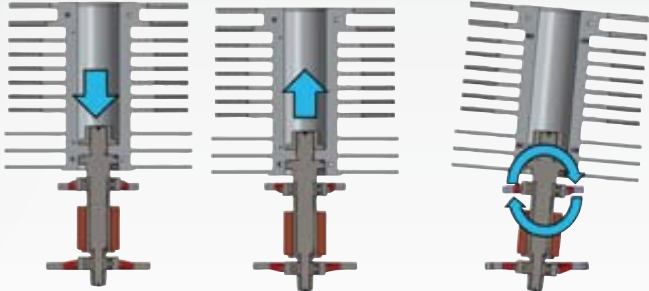

# TURBO PUMP TECHNOLOGY

## Wide Pumping Speed Range: 80 to 2,200 l/s

Agilent offers a complete range of turbomolecular pumps, to cover all applications and market segments.

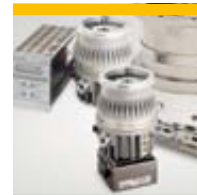

### Controllers

- Various configurations available to match each application's requirements
- Rack type display controllers, to match your existing system architecture
- Low voltage - PCB units, to fully integrate turbopump electronics into your system's electronics
- Navigator on board controllers, for plug-and-pump operation driven by the computer of your system
- Truly integrated electronics, completely embedded in the pump body

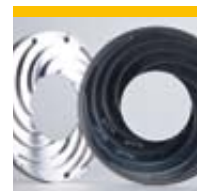

### Molecular Drag Technology & Pumping Efficiency

- MacroTorr and TwisTorr technologies allow higher foreline pressure, higher efficiency and smaller backing pump, in a very compact design
- Agilent R&D Team has the capability to optimize the pump performances for different applications

# TURBO PUMPS

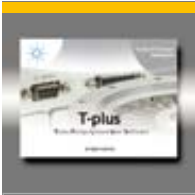

## Controller and T-plus SW

- T-plus Software runs on a PC or laptop and is an effective operation and trouble shooting interface
- It enables complete remote control of the pump
- It is available for all controllers, when equipped with serial port, for data logging and displaying

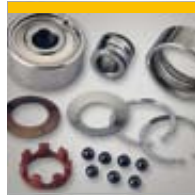

## Ceramic Ball Bearings

- Agilent was the first to introduce permanently lubricated ceramic ball bearings in turbomolecular pumps in 1992
- From there, bearings' quality and reliability have dramatically improved
- Now typical MTTF well exceeds 200,000 hours



## Application Specific Solutions for SEM

A complete line of turbo pumps dedicated to Electron Microscopy.  
(See page 12-13)



## Oil Free - Permanent Lubrication

- Permanent lubrication is possible thanks to the extremely low vapor pressure of the solid lubricant
- This solution allows pump operation in any position
- No maintenance, no oil, no refill and most important no contamination

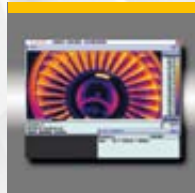

## Thermal Efficiency & Temperature Control

- The correct design of pumping stages, motor and electronics allows low heat dissipation and low power consumption
- Total temperature control within the pump is important for reliable long- term operation. All our pumps are equipped with at least one temperature sensor
- Controllers manage temperature information related to other operational parameters, for an evenly distributed and controlled temperature within the pump
- These, in combination with efficient air and water cooling systems, are key factors for reliability, in any application

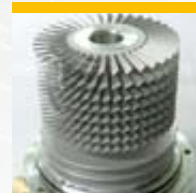

## Rotor

- Suspension axial/radial perfect positioning
- Vibration damping
- Correct bearing pre-load



# TURBO PUMP TECHNOLOGY FOR INSTRUMENTATION

## The Agilent Advantage: Masters in Mass Spec and Nanotechnology

As the leading Ultra-High Vacuum products supplier, Agilent Technologies has long been working with all MS, SEM and TEM manufacturers, providing application specific solutions.

Today Agilent is the only company able to offer a complete and dedicated range of MS and SEM products, including primary pumps, turbomolecular pumps, ion getter pumps, and vacuum measurement, that meet the most stringent requirements of the industry.

Turbo-V SEM versions are available on request; please ask Agilent for technical details.

### Vacuum for SEM: basic requirements

- Vacuum in the gun and sample chamber must be particle-free and oil-free
- **No** Vibrations
- **No** Resonances
- **No** Magnetic stray fields from both IGP and TMPs
- **No** Electric noise from power supplies
- **Fastest** Pumpdown cycles
- Pressure levels stable and controlled
- Maximum Uptime
- Fast, worldwide Service Support



#### Superior Vibration Isolation System

- Lower vibrations than Mag-Lev!
- Certified Computer Aided Balancing, thanks to suspended benches with special high sensitivity accelerometers



#### Foreline Pressure up to 15 mbar

- Ideal to minimize forepump size (i.e. IDP-3 Dry Scroll Pump, DS 42 Rotary Vane Pump), resulting in the lowest cost of ownership

# TURBO PUMPS

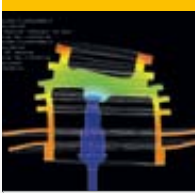

## Improved Roto Dynamics

- Designed to avoid internal mechanical resonances
- Agilent SEM turbopumps are designed to minimize vibration sources, and have a very stable vibration profile



## Enhanced Electronic Controllers

- Universal voltages
- Integrated Vent valve command, adjustable valve delay and opening time
- Pressure gauge reading
- Integrated Profibus

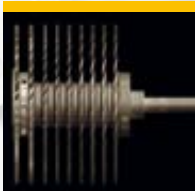

## Monolithic Rotor

Mounting in any position, with no limitations.

- Rugged design
- Light weight
- Air inrush proof
- Earthquake proof



## Magnets Free Design

- Lowest Magnetic Signature in the industry
- Best to work very close to ebeams
- No need for magnetic shields

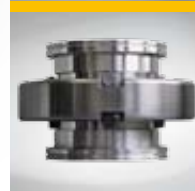

## Integrated Double Dampers

- Agilent developed special Integrated Double Dampers for the most demanding SEM applications
- Damping factor up to 1400X (Radial, at unbalance level, with IDD100 ISOK): better than Mag-Lev!
- Best SEM image resolution

# AGILENT TURBO PUMPS TYPICAL APPLICATIONS

## Research and Development Particle Accelerators

- Turbomolecular pumps are widely used in High Energy Physics, Fusion Technology and general UHV research. Synchrotron Light Sources, Particle Accelerator Rings, UHV Laboratory research, and Fusion reactors need extremely clean, reliable and cost effective HV and UHV.F Maintenance-free pumps are specifically required, because most pumps are not easily accessible.
- Agilent turbomolecular pumps are designed to offer unmatched reliability, performance and cleanliness for these applications.  
Ceramic bearing pumps, thanks to their reduced rolling friction, low stress and high thermal stability compared to conventional bearings, deliver longer operating life. Ultra low vapor pressure solid lubricant eliminates the need for maintenance and assures clean operation under any operating conditions.
- Furthermore, in contrast to most of the other pumps, all Agilent turbopumps have both the upper and the lower bearing in the rough vacuum side and not exposed to UHV, further reducing the possibility of contamination - even in case of misuse.

- The patented TwisTorr stages provide the highest speed and compression ratio in the smallest footprint; furthermore all Agilent turbopumps can truly be mounted in any orientation, from vertical to horizontal to upside down, aiding system design in the most stringent space requirements.
- Agilent turbopumps can operate at higher foreline pressures, allowing the use of dry roughing pumps, thus providing a completely clean, oil-free compact and cost effective pumping package.
- Whenever a large amount of gas has to be pumped and higher throughput is needed, the combination of TwisTorr pumps and TriScroll dry pumps is the state-of-the-art solution. All Agilent turbopumps have integrated or on board controller versions allowing easy plug and pump operation, or a rack-mounted controller for applications where the electronics need to be remotely placed (i.e. radioactive environments).

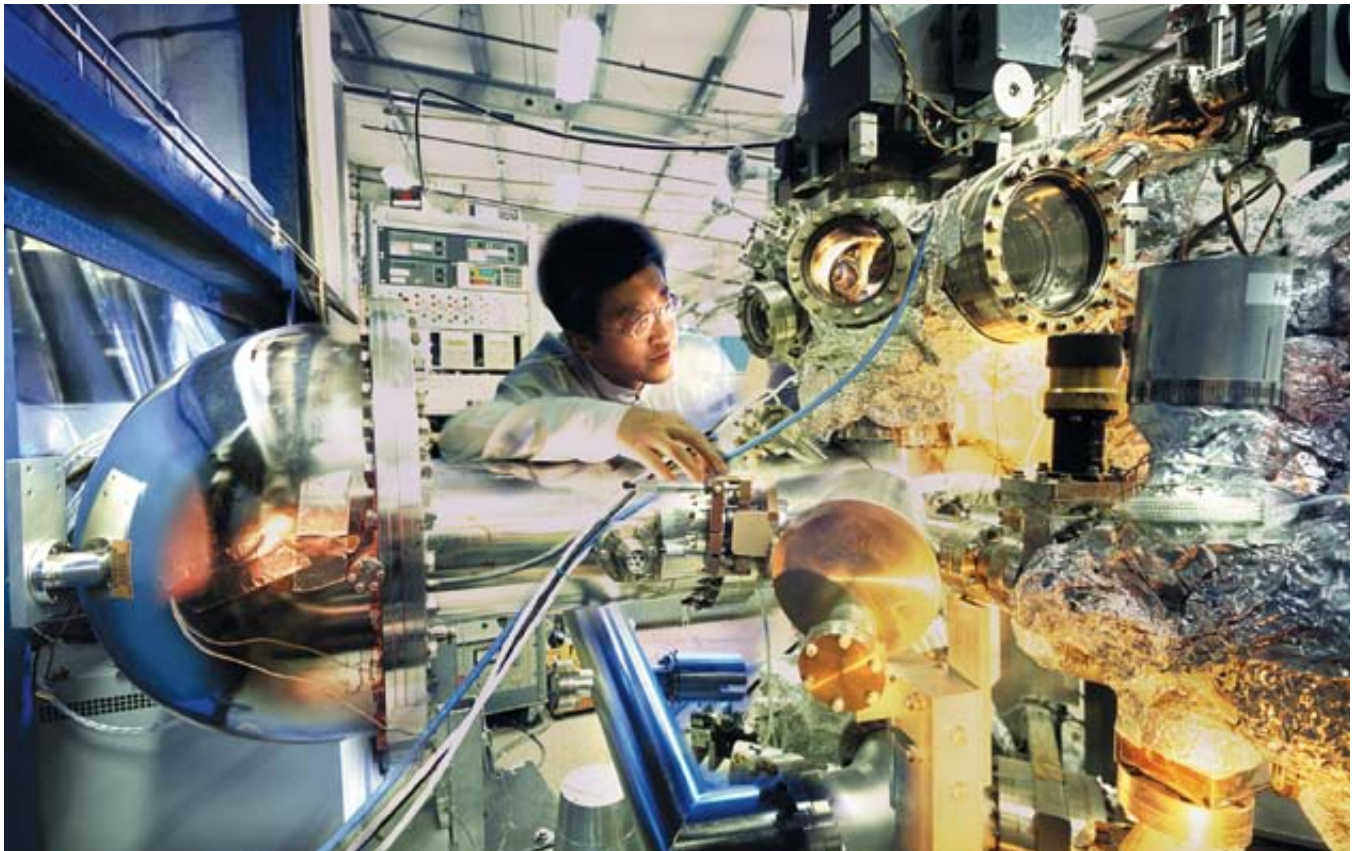





Courtesy TRIUMF-ISAC.

## Instrumentation

### Electron Microscopy (SEM, TEM), Focused Ion-beam Systems (FIB) and Surface Analysis

- Modern focused-beam systems such as SEM's, TEM's and FIB's utilize columns that project electrons or ions onto microscopic samples for detailed analysis. End users analyze all types of substances from organic compounds to semiconductor wafers. In the Semiconductor industry, in particular, they require more sensitivity for better sample resolution. Another key requirement is high sample throughput in order to lower the cost of ownership of these instruments.
- Based on these requirements, the demand for high performance vacuum pumps is greater than ever. Agilent offers a full range of high and ultra-high vacuum pumps designed especially for the demanding requirements of SEM's, TEM's and surface analysis systems (Agilent has a full range of ion pumps, which are key products for this application; please see ion pump section).
- Turbo molecular pumps are also a key component in modern focused-beam systems because they offer fast, oil-free air evacuation of large sample chambers (oil-free operation is a key requirement of many modern analysis applications such as semiconductor manufacturing). From Agilent's full range of turbo pumps, the focused-beam system designer can choose a pump size that offers the best chamber evacuation time with the best cost of ownership and compact size for use in limited space situations.
- Agilent has a full line of customized, low vibration turbo pumps for the most sensitive microscopy applications. Finally, Agilent has a full range of integrated pump controllers that offer the highest control flexibility with near zero electromagnetic noise generation.
- **Agilent offers a full range of application specific designed SEM turbo pumps including 80 l/s, 300 l/s, 550 l/s, 700 l/s and 1000 l/s speeds.**

All of Agilent's SEM turbo pumps designs can be verified in Agilent's application lab. Finally, each SEM turbo pump is tested in production before being shipped to the customer.

### Mass Spectrometry

MS is our core business and has become a fundamental analytical tool in many industries. Thanks to advances in electronics, instrument designers can implement cost-effective, high-performance analytical power in a cost-effective, easy-to-use system.

These developments require advanced vacuum systems that are characterized by multi-chamber, high throughput designs on the high quality instruments.

These requirements, in turn, demand cost-effective, high performance vacuum pumps.

Agilent offers a full line of pumps and controllers that meet the most challenging vacuum requirements and are optimized for the specific requirements of modern mass spectrometry systems.



# AGILENT TURBO PUMPS TYPICAL APPLICATIONS

Agilent can further customize its pumps by providing multi-inlet pumping systems that are compact and reliable. A few common application examples for mass spectrometry are listed below:

- **GC-MS**

Gas Chromatograph Mass Spectrometers typically use one vacuum chamber in relatively low gas load environments and an intermediate vacuum interface to analyze inorganic samples.

The Agilent Turbo-V 81 with printed circuit board controller (PCB) is a very cost-effective solution for this common analytical technique. The V 301 Navigator offers a compact, cost-effective solution for larger instrument designs.

- **LC-MS**

Liquid Chromatograph Mass Spectrometers typically include multi-chamber, high throughput vacuum systems.

Agilent's turbomolecular pumps are designed for high throughput operation with air cooling – an important benefit for maintaining a compact system. They are also available in several split flow versions to increase their utility and performance in this application.

The integrated controller provides a high level of control function in a small package.

- **ICP-MS**

Inductively Coupled Plasma-MS systems have a wide range of vacuum requirements. Many systems can use heavy carrier gases such as argon, while collision cell designs use helium.

Agilent turbopumps have a high efficiency motor and TwisTorr or MacroTorr drag stages to reduce heat production under gas load. These features allow to pump high levels of argon. Integrated or on board controllers assure compact package.

- **TOF**

Time Of Flight systems are becoming very important analytical tools in drug discovery and proteomics. Vacuum requirements vary, although small size is often an important consideration.

Agilent turbopump and controller package provides the TOF designer with a high degree of flexibility with regard to high throughput, efficient heat dissipation and compact size.



## Industrial Vacuum Processing

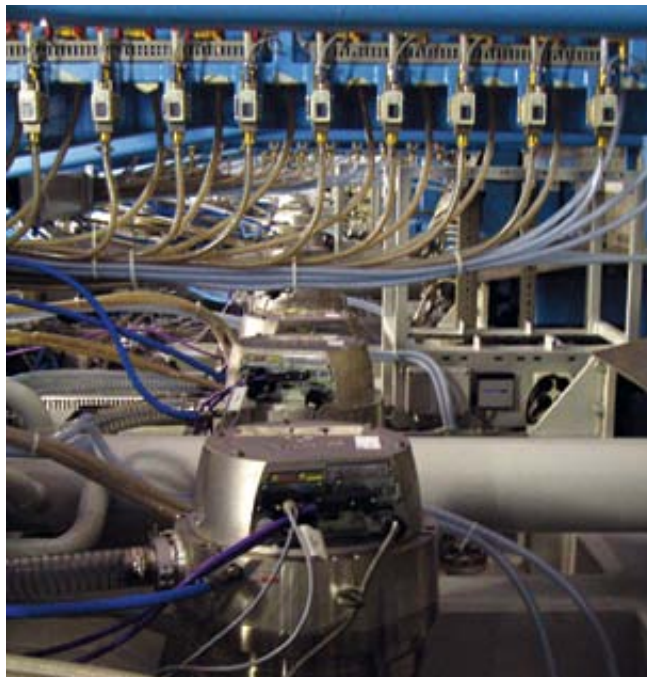

*Agilent Turbo-V 2K-G in Thin Film Deposition application.*

- In a wide range of industries, from glass coating to medical equipment, manufacturers share a need for robust, reliable, production-friendly vacuum technologies.
- Focusing on the total cost of ownership, Agilent continues to deliver innovative vacuum solutions that maximize throughput, tolerate varying operating conditions, and simplify maintenance, helping to assure maximum uptime and efficiency.
- Turbo-V pumps, designed to withstand heavy industrial use, can handle high gas loads and will recover quickly from accidental air in-rushes.
- Agilent offers a comprehensive range of vacuum pumps and systems for industrial uses, including the new Turbo-V K-G Series, with truly integrated electronics embedded in the pump body.

### Thin Film Deposition

- Glass coating equipment (architectural glass, automotive

# TURBO PUMPS

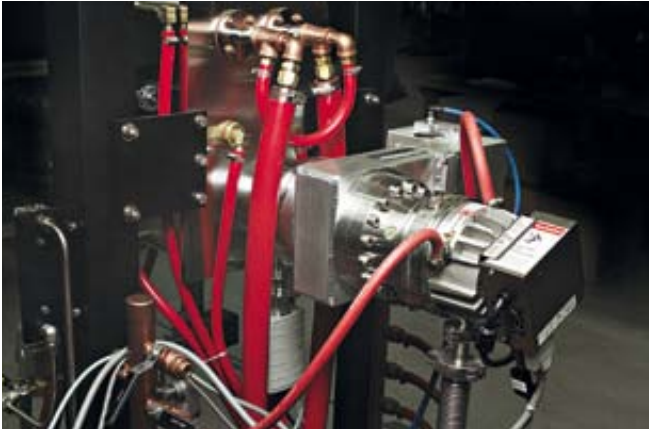

Courtesy Centorr.



Courtesy Optovac Vacuum Coating Systems.

- glass, flat panel display substrates)
- Thin film solar cells production (photo-voltaic)
- Optical data media (Compact Discs, Digital Versatile Discs, Magneto Optical Discs)
- Magnetic storage media (hard discs, read heads)
- Surface treatments used for Tribological and Wear coatings
- Functional and Decorative coatings, including Metallization
- Optical coating (ophthalmic, precision opto-electronics)
- Roll/Web coating on films or foils
- PVD and other Plasma Process systems requiring high gas load

## Device Processing:

- TV & Monitor picture tube manufacture
- Evacuation of lamps (motorway lighting, beamers)
- X-Ray tubes & electron devices
- Medical accelerator tubes
- Lasers

## General Industrial Processes:

- Vacuum furnaces / Brazing
- Electron beam welding

## Dedicated Solutions for Thin Film Deposition

- In single chamber batch systems, multiple chamber systems, with load locks, or large inline continuous systems, Agilent has the right turbo pump for your process requirements. What really differentiates Agilent is the expertise of its applications, support and custom system design staff to integrate vacuum pumps into optimized vacuum solutions.

## The Turbo-V K-G Series Systems

- Application-specific pumping solutions designed for thin film deposition equipment: the first fully integrated approach for maximum system productivity and uptime.
  - high pumping speed and high gas throughput
  - truly integrated power supply (Protection Class IP 54),



- resulting in compact size and ease of system integration
- capability to create differentiated partial pressures where needed
- maximum throughput capacity at stable operation pressure
- ceramic ball bearings, oil-free, contamination-free, no preventive maintenance, make the pump mountable in any position
- extremely low vibration and noise for sensitive applications
- water cooling (water compatibility up to 35 °C) allows long service life of electronic components
- permanent monitoring system integrated in the electronic device, and built-in self-diagnostics capability, in combination with our tailored service & support plans offers a unique solution for TFD applications.



# AGILENT TURBO PUMPS MODELS

		Turbo-V 81 T		Turbo-V 81 M		TwisTorr 304 FS		Turbo-V 551 Navigator		Turbo-V 701 Navigator
Pump specification		DN 40	DN 63	DN 40	DN 63	DN 100	DN 160	DN 100	DN 160	DN 200
Pumping speed, l/s	Nitrogen	50	77	50	77	250	250	350	550	690
	Helium	56	65	56	65	255	255	450	600	620
	Hydrogen	46	50	46	50	220	220	450	510	510
	Argon					250	250			
Compression ratio	Nitrogen	$7 \times 10^8$		$3 \times 10^8$		$>1 \times 10^{11}$		$>1 \times 10^9$		$1 \times 10^9$
	Helium	$3 \times 10^3$		$8 \times 10^4$		$>1 \times 10^8$		$1 \times 10^7$		$1 \times 10^7$
	Hydrogen	$3 \times 10^2$		$7 \times 10^3$		$1.5 \times 10^6$		$1 \times 10^6$		$1 \times 10^6$
	Argon					$>1 \times 10^{11}$				
Base pressure, mbar	With recommended mechanical pump	$5 \times 10^{-9}$		$5 \times 10^{-10}$		$<1 \times 10^{-10}$		$<1 \times 10^{-10}$		$<1 \times 10^{-10}$
	With recommended dry pump	$5 \times 10^{-8}$		$5 \times 10^{-9}$				$<1 \times 10^{-10}$		$<1 \times 10^{-10}$
Startup time, min	< 1		< 1		< 3		< 5		< 5	
Rotational speed, rpm	80,000		80,000		60,000		42,000		42,000	
Recommended forepump	Mechanical pump	DS 42, DS 102		DS 42, DS 102		DS 102		DS 302		DS 302
	Dry pump	SH-110, IDP-3		SH-110, IDP-3		SH-110		IDP-15		IDP-15
Inlet flange, nominal diameter	Klamp flange, mm	40	–	40	–	–	–	–	–	–
	ConFlat, mm (inches OD)	35 (2.75)	63 (4.5)	35 (2.75)	63 (4.5)	100 (6)	160 (8)	100 (6)	160 (8)	200 (10)
	ISO clamp style, mm	–	63	–	63	100	160	–	160	200
	ISO-F bolted, mm	–	–	–	–	–	–	–	160-F bolted	200-F bolted
Foreline flange, nominal diameter	Klamp flange	NW16		NW16		NW16 (NW25 optional)		NW25		NW25
SEM version available on request	–		•		–		•		•	
<b>Controllers</b>	Rack controller	•		•		•		•		•
	Navigator on board contr.	•		•		•		•		•
	Integrated electronics	–		–		–		–		–
	PCB controller	•		•		–		–		–

\*Rack version



# TURBO PUMPS

Turbo-V 750 TwisTorr		Turbo-V 850 TwisTorr	Turbo-V 1001 Navigator			Turbo-V 2300 TwisTorr	Turbo-V 1K-G		Turbo-V 2K-G System	Turbo-V 3K-G System
DN 100*	DN 160	DN 200	DN 160	DN 200	DN 250	DN 250	DN 160	DN 200	DN 250	DN 250
370*	700	750	790	950	1,050	2,050	810	1,080	1,600	2,200
500*	680	690	820	870	900	1,800	950	1,150		
470*	580	590	860	900	920	1,500	680	730		
340*	680	700					750	1,040		
1 x 10 <sup>11</sup>	1 x 10 <sup>11</sup>		1 x 10 <sup>9</sup>			>8 x 10 <sup>8</sup>	>5 x 10 <sup>7</sup>		3 x 10 <sup>5</sup>	>1 x 10 <sup>7</sup>
2 x 10 <sup>8</sup>	2 x 10 <sup>8</sup>		1 x 10 <sup>7</sup>			8 x 10 <sup>5</sup>	>4 x 10 <sup>4</sup>			
2.5 x 10 <sup>6</sup>	2.5 x 10 <sup>6</sup>		1 x 10 <sup>6</sup>			4 x 10 <sup>4</sup>	1.5 x 10 <sup>4</sup>			
1 x 10 <sup>11</sup>	1 x 10 <sup>11</sup>						>5 x 10 <sup>8</sup>			
<1 x 10 <sup>-10</sup>	<1 x 10 <sup>-10</sup>		<1 x 10 <sup>-10</sup>			10 <sup>-10</sup>	<1 x 10 <sup>-10</sup>		<1 x 10 <sup>-8</sup>	<1 x 10 <sup>-9</sup>
			<1 x 10 <sup>-10</sup>				<1 x 10 <sup>-10</sup>		<1 x 10 <sup>-8</sup>	<1 x 10 <sup>-9</sup>
< 6	< 3		< 4			< 6	< 5		< 7	< 6
50,000	50,000		38,000			33,300	45,660		33,000	31,800
DS 302 IDP-15	DS 302 IDP-15		DS 402 IDP-15			DS 602 TS600	>20 m <sup>3</sup> /h >36 m <sup>3</sup> /h		>40 m <sup>3</sup> /h	>60 m <sup>3</sup> /h
-	-	-	-	-	-	-	-	-	-	-
100 (6)	160 (8)	200 (10)	-	200 (10)	-	250 (12)	-	-	-	-
-	160	200	160	200	250	-	-	-	-	-
-	160	200	-	200-F bolted	250-F bolted	250-F bolted	160-F	200-F	250-F bolted	250-F bolted
NW25	NW25 NW40		NW40			NW40	NW25	NW40	NW40	NW40
-	-		•			-	-	-	-	-
•	•		•			•	•	-	-	-
-	-		•			-	•	•	-	-
•	•		-			-	-	•	-	•
-	-		-			-	-	-	-	-

Turbo Pumps



# AGILENT TURBO PUMP MODELS

## ▶ Agilent Turbo-V 81-T

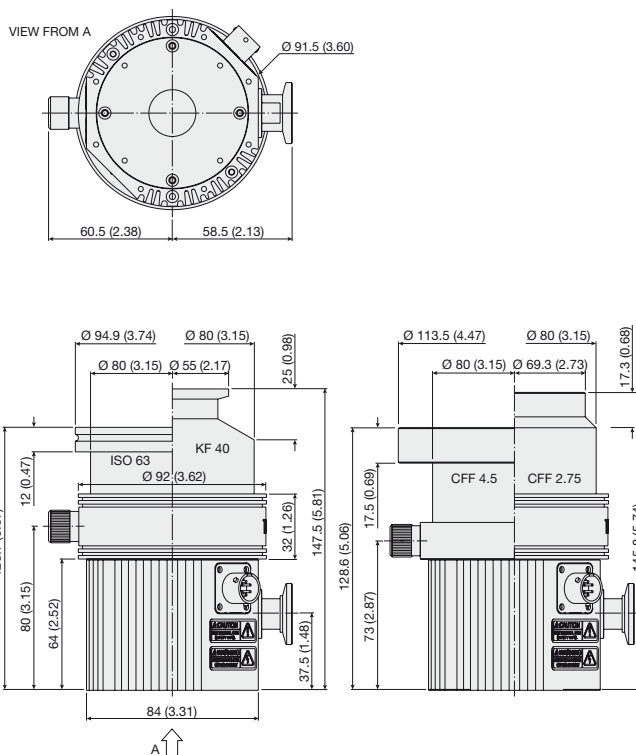

Dimensions: millimeters (inches)

### Technical Specifications

<b>Pumping speed (l/s)</b>			
With CFF 4 ½" or ISO 63:	N <sub>2</sub> : 77 l/s	He: 65 l/s	H <sub>2</sub> : 50 l/s
With CFF 2 ¾" or KF 40:	N <sub>2</sub> : 50 l/s	He: 56 l/s	H <sub>2</sub> : 46 l/s
<b>Compression ratio</b>	N <sub>2</sub> : >7 x 10 <sup>6</sup>	He: 3 x 10 <sup>3</sup>	H <sub>2</sub> : 3 x 10 <sup>2</sup>
<b>Base pressure*</b> (with recommended forepump)	5 x 10 <sup>-9</sup> mbar (3.8 x 10 <sup>-9</sup> Torr)		
<b>Inlet flange</b>	CFF 4 ½" O.D. CFF 2 ¾" O.D.	ISO 63 KF 40	
<b>Foreline flange</b>		KF 16 NW	
<b>Rotational speed</b>		1350 Hz (max)	
<b>Start-up time</b>		< 60 seconds	
<b>Recommended forepump</b>		Mechanical: Agilent DS 42 – DS 102 Dry pump: Agilent IDP-3, SH 110	
<b>Operating position</b>		Any	
<b>Cooling requirements</b>		Natural air convection Forced air or water optional	
<b>Bakeout temperature</b>		120 °C at inlet flange max. (CF flange) 80 °C at inlet flange max. (ISO flange)	
<b>Vibration level</b> (displacement)		<0.01 µm at inlet flange	
<b>Weight kg (lbs)</b>		ISO 63: 1.82 (4) CFF 4 ½": 2,68 (5.90)	

\* According to standard DIN 28 428.

**NOTE** • The pump is available with On-board Navigator controller, ¼ Rack controller or PCB controller; for information on controllers see also following pages.



# TURBO PUMPS

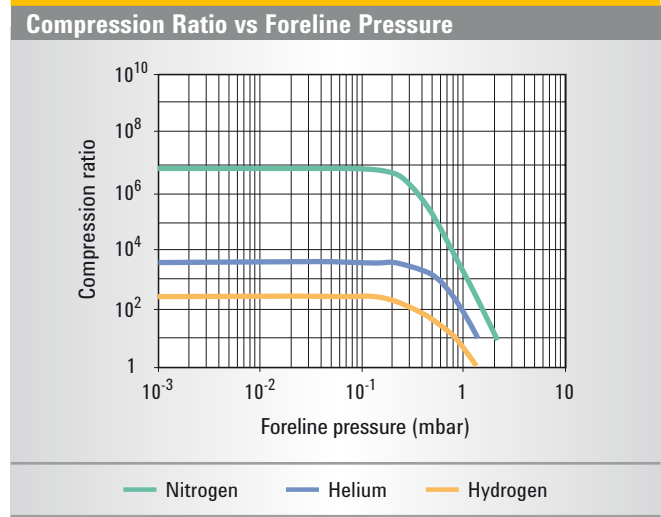
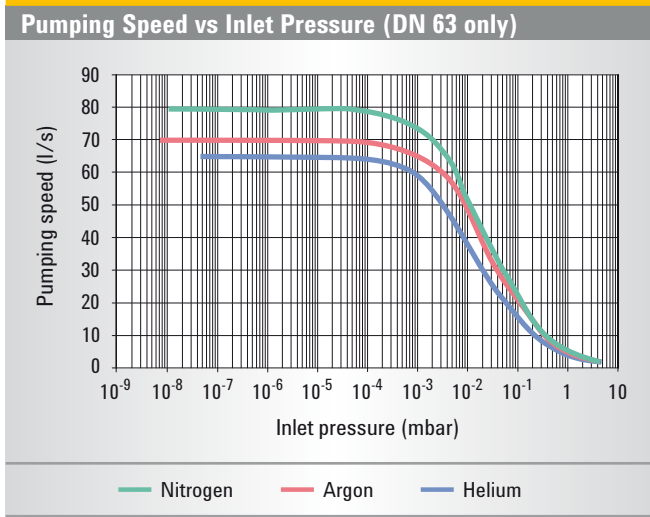

## Ordering Information

Description	Weight kg (lbs)	Part Number
<b>Pumps</b>		
Turbo-V 81-T pump with ISO 63 inlet flange	1.82 (4.0)	9698905
Turbo-V 81-T pump with CF 4 ½" inlet flange	2.68 (5.9)	9698907
Turbo-V 81-T pump with KF 40 inlet flange	1.82 (4.0)	9698906
Turbo-V 81-T pump with CF 2 ¾" inlet flange	2.68 (5.9)	9698908
<b>Controllers</b> (See following pages for specifications)		
Turbo-V 81-AG Navigator controller 100-240 Vac	0.3 (0.66)	9698996
Turbo-V 81-AG Navigator controller 24 Vdc	0.3 (0.66)	9698995
Turbo-V 81-AG Rack controller base	1.7 (3.2)	9698988
Turbo-V 81-AG Rack controller RS232/485	1.7 (3.2)	9698989
Turbo-V 81-AG Rack controller Profibus	1.7 (3.2)	9698990
Turbo-V 81 PCB controller 24 Vdc	1.0 (2.2)	9699538
<b>Pump Accessories</b>		
Mains cable NEMA plug, 3 m long		9699958
Mains cable European plug, 3 m long		9699957
Serial cable and T-Plus Software		9699883
Inlet screen, KF 40		9699309
Inlet screen, CFF 4 ½" - ISO 63		9699300
Inlet screen, CFF 2 ¾"		9699328
Heater band 220 V		9699801
Heater band 120 V		9699802
Metallic water cooling kit		9699823
Plastic water cooling kit		9699824
Air cooling kit (0.5 m cable)		9699290
Air cooling kit extension cable (5 m)		9699940
Pump extension cable (3 m)		9699942
Vent valve N.O. 0.5 orifice (0.5 m cable)		9699844
Vent valve extension cable (5 m)		9699941
Vibration damper DN 63	0.5 (1.0)	9699375
Vibration damper CFF 4.5"	0.5 (1.0)	9699376
Vent flange KF 10	0.5 (1.0)	9699108
Active Gauges and cables	See Control Units section (pages 24-25)	
<b>Recommended Forepump</b>		
Mechanical pump DS 42	11.0 (24.0)	9499309
Mechanical pump DS 102	22.0 (48.0)	9499315
Dry scroll SH 110	19.0 (43.0)	SH01101 UNIV
Dry scroll IDP-3	9.5 (21.0)	Please see Dry Scroll Pump section

Turbo Pumps

# AGILENT TURBO PUMP MODELS

## ▶ Agilent Turbo-V 81-M

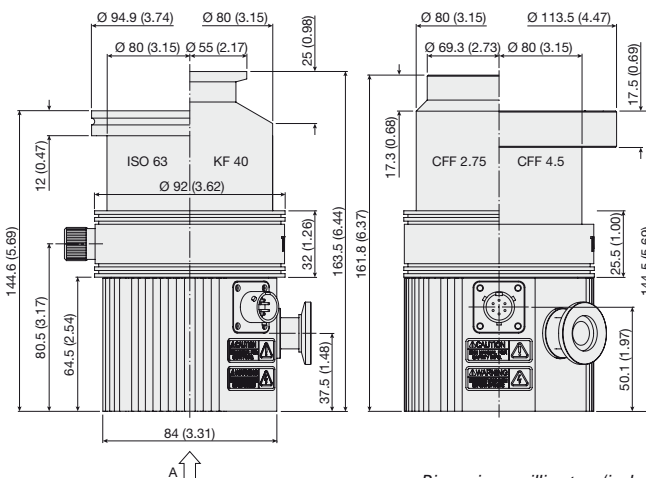
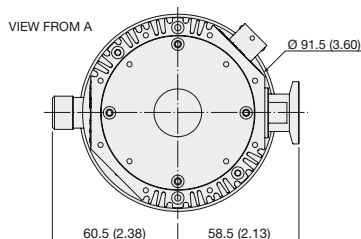

Dimensions: millimeters (inches)

### Technical Specifications

<b>Pumping speed (l/s)</b>			
With CFF 4 1/2" or ISO 63:	N <sub>2</sub> : 77 l/s	He: 65 l/s	H <sub>2</sub> : 50 l/s
With CFF 2 3/4" or KF 40:	N <sub>2</sub> : 50 l/s	He: 56 l/s	H <sub>2</sub> : 46 l/s
<b>Compression ratio</b>	N <sub>2</sub> : 5 x 10 <sup>8</sup>	He: 8 x 10 <sup>4</sup>	H <sub>2</sub> : 7 x 10 <sup>3</sup>
<b>Base pressure*</b> (with recommended forepump)	5 x 10 <sup>-10</sup> mbar (3.8 x 10 <sup>-10</sup> Torr)		
<b>Inlet flange</b>	CFF 4 1/2" O.D. CFF 2 3/4" O.D.	ISO 63 KF 40	
<b>Foreline flange</b>		KF 16 NW	
<b>Rotational speed</b>		1350 Hz (max)	
<b>Start-up time</b>		< 60 seconds	
<b>Recommended forepump</b>		Mechanical: Agilent DS 42 – DS 102 Dry pump: Agilent IDP-3, SH 110	
<b>Operating position</b>		Any	
<b>Cooling requirements</b>		Natural air convection Forced air or water optional	
<b>Bakeout temperature</b>		120 °C at inlet flange max. (CF flange) 80 °C at inlet flange max. (ISO flange)	
<b>Vibration level (displacement)</b>		<0.01 µm at inlet flange	
<b>Weight kg (lbs)</b>		ISO 63: 2 (4.4) CFF 4 1/2": 2.98 (6.57)	

\* According to standard DIN 28 428.

**NOTE** • The pump is available with On-board Navigator controller, 1/4 Rack controller or PCB controller; for information on controllers see also following pages.

# TURBO PUMPS

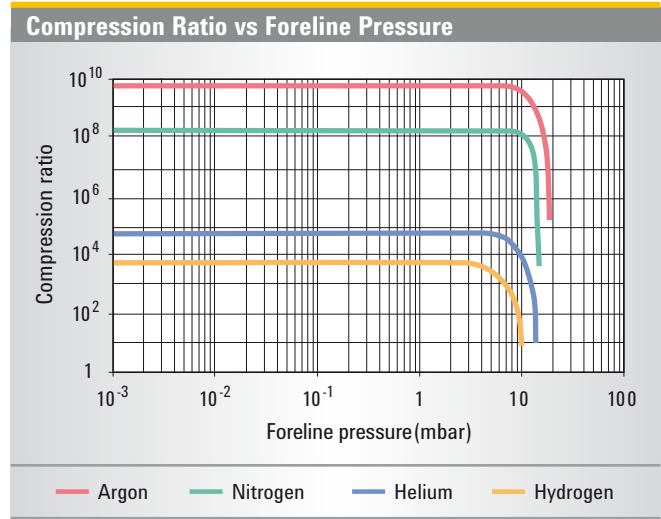
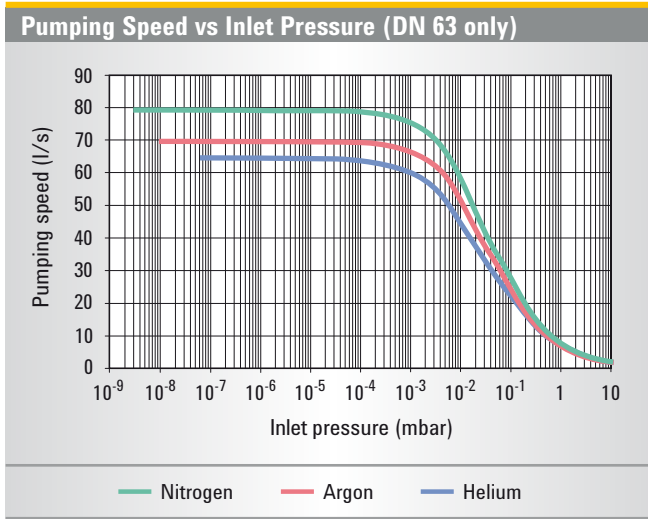

## Ordering Information

Description	Weight kg (lbs)	Part Number
<b>Pumps</b>		
Turbo-V 81-M pump with ISO 63 inlet flange	2.0 (4.4)	9698901
Turbo-V 81-M pump with CFF 4 ½" inlet flange	2.98 (6.57)	9698903
Turbo-V 81-M pump with KF 40 inlet flange	2.0 (4.4)	9698902
Turbo-V 81-M pump with CFF 2 ¾" inlet flange	2.98 (6.57)	9698904
<b>Controllers</b> (See following pages for specifications)		
Turbo-V 81-AG Navigator controller 100-240 Vac	0.3 (0.66)	9698996
Turbo-V 81-AG Navigator controller 24 Vdc	0.3 (0.66)	9698995
Turbo-V 81-AG Rack controller base	1.7 (3.2)	9698988
Turbo-V 81-AG Rack controller RS232/485	1.7 (3.2)	9698989
Turbo-V 81-AG Rack controller Profibus	1.7 (3.2)	9698990
Turbo-V 81 PCB controller 24 Vdc	1.0 (2.2)	9699538
<b>Pump Accessories</b>		
Mains cable NEMA plug, 3 m long		9699958
Mains cable European plug, 3 m long		9699957
Serial cable and T-Plus Software		9699883
Inlet screen, KF 40		9699309
Inlet screen, CFF 4 ½" - ISO 63		9699300
Inlet screen, CFF 2 ¾"		9699328
Heater band 220 V		9699801
Heater band 120 V		9699802
Metallic water cooling kit		9699823
Plastic water cooling kit		9699824
Air cooling kit (0.5 m cable)		9699290
Air cooling kit extension cable (5 m)		9699940
Pump extension cable (3 m)		9699942
Vent valve N.O. 0.5 orifice (0.5 m cable)		9699844
Vent valve extension cable (5 m)		9699941
Vibration damper DN 63	0.5 (1.0)	9699375
Vibration damper CFF 4.5"	0.5 (1.0)	9699376
Vent flange KF 10	0.5 (1.0)	9699108
Active Gauges	See Control Units section (pages 24-25)	
<b>Recommended Forepump</b>		
Mechanical pump DS 42	11.0 (24.0)	9499309
Mechanical pump DS 102	22.0 (48.0)	9499315
Dry scroll SH 110	19.0 (43.0)	SH01101 UNIV
Dry scroll IDP-3	9.5 (21.0)	Please see Dry Scroll Pump section

Turbo Pumps



# AGILENT TURBO PUMP CONTROLLERS

## ▶ Agilent Turbo-V 81-AG Navigator Controller

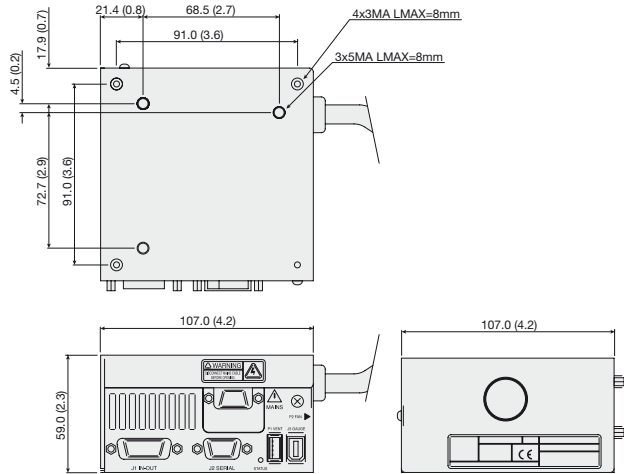

Dimensions: millimeters (inches)

The Turbo-V 81-AG Navigator controller is a solid-state frequency converter with the following features:

- Drives the pumps of the Turbo-V 81 family
- Powers the pump cooling fan
- Drives the vent valve
- Provides and acquires the pressure of the wide range gauge.
- Remote I/Os compatible with the previous version
- Navigator default serial compatible with the previous RS 232 and 485 version
- Able to operate with Active Gauges (Full Range Gauge FRG-700 and FRG-702)

The dedicated controller is a solid-state frequency converter which is driven by a single chip microcomputer and consists of two PCBs which include power supply and 3-phase output, analog and input/output section, microprocessor and digital

section. The power supply, together with the 3-phase output, converts the single phase AC mains supply or 24Vdc supply into a 3-phase, low voltage, medium frequency output which is required to power the pump. The controller can be operated by a remote host computer via the serial connection. A Windows-based software is available (optional).

The Turbo-V 81-AG Navigator controller can be mounted on board, on the bottom of the Turbo-V 81 Series pumps.

### Ordering Information

Description	Weight kg (lbs)	Part Number
<b>Controllers</b>		
Turbo-V 81-AG Navigator controller*, 24 Vdc	0.3 (0.66)	9698995
Turbo-V 81-AG Navigator controller*, 100/240 Vac	0.3 (0.66)	9698996

\* Order power cable separately

### Accessories

Mains cable NEMA Plug, 3 m long	9699958
Mains cable European Plug, 3 m long	9699957
Serial cable and T-Plus Software	9699883
Air cooling kit (0.5 m)	9699290
Air cooling kit, extension cable (5 m)	9699940
Vent valve N.O. 0.5 mm orifice (0.7 m cable)	9699844
Vent valve extension cable (5 m, USB Type A - USB Type A)	9699941

### Active Gauges

FRG-700 Pirani/IMG Combination Gauge, KF25	FRG700KF25
FRG-700 Pirani/IMG Combination Gauge, DN40 CF	FRG700CF35
FRG-702 Pirani/IMG Combination Gauge, KF25 All metal - bakeable	FRG702KF25
FRG-702 Pirani/IMG Combination Gauge, DN40 CF All metal - bakeable	FRG702CF35
Gauge connection cable to AG rack controller - 3 m	9699960
Gauge connection cable to AG rack controller - 5 m	9699961

### Technical Specifications

<b>Input voltages:</b>	
Navigator controller, 24 Vdc	24 Vdc $\pm 10\%$
Navigator controller, 100/240 Vac	100 $\div$ 240 Vac $\pm 10\%$
<b>Input power:</b>	
Navigator controller, 24 Vdc	80 W
Navigator controller, 100/240 Vac	180 VA
<b>Input frequency:</b>	
Navigator controller, 100/240 Vac	50 to 60 Hz $\pm 5\%$
<b>Fuse</b>	2 x T4 A 250 V
<b>Output voltage</b>	60 Vac
<b>Output frequency</b>	1350 Hz
<b>Output power:</b>	
Navigator controller, 24 Vdc	50 W
Navigator controller, 100/240 Vac	70 W (ramp), 50 W (Normal and Autotuning)
<b>Operating temperature</b>	+5 $\div$ +45 °C 0 – 90% (Not condensing)
<b>Storage temperature</b>	-20 °C to +70 °C 0 – 95%

## ▶ Agilent Turbo-V 81-AG Rack Controller

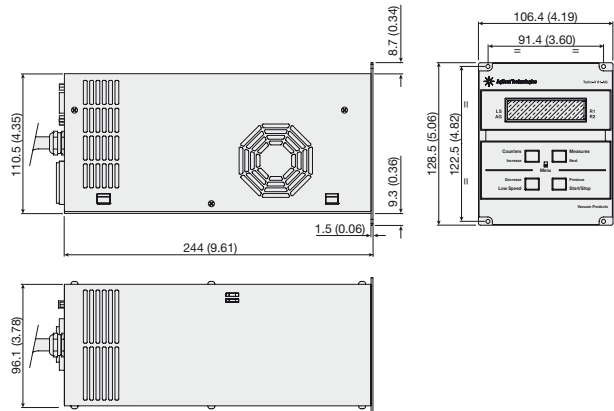

Dimensions: millimeters (inches)

The Turbo-V 81-AG Rack controller is a microprocessor-controlled frequency converter with new, enhanced features that allow greater control and communication capabilities. This compact, ¼ rack unit is designed for full worldwide compatibility, for vent valve control, active gauge pressure reading and pump operation parameters control, as well as for self diagnostic and protection features.

- **Universal Voltage**

Controller able to auto set according to the input voltage, providing flexibility for easy installation worldwide

- **RS-232/485 Communication Protocols and Profibus (Options)**

- Allows the pump to be interfaced with the system controls
- Enables the pump to be operated via PC with T-Plus software
- Helps development of own customer software

- **Stop Speed Reading (SSR)**

- Continues pump speed reading after the stop command
- Allows monitoring the pump in slow down ramp and shut down time

- **N.O. and N.C. Vent Valve Drive**

- Valve delay and opening time adjustable
- Vent valve driven by controller automatically or by serial line
- Opening time control through SSR function

### Technical Specifications

<b>Input</b>	100 ÷ 240 Vac
	50/60 Hz
<b>Maximum input power</b>	210 VA
<b>Output voltage</b>	76 Vac
<b>Output frequency</b>	1,350 Hz
<b>Nominal output power</b>	100 W
<b>Operating temperature</b>	+5 °C to +45 °C
<b>Storage temperature</b>	-20 °C to +70 °C

- **Active Gauge Pressure Reading Capability**

- Able to operate with Active Gauges (Full Range Gauge FRG-700 and FRG-702)
- Provides accurate pressure measurements from atm down to 10<sup>-9</sup> mbar
- Rack mounted control electronics no longer necessary, with simple +24 Vdc power connector
- Proven inverted magnetron design
- Rapid start even in high-vacuum conditions

### Ordering Information

Description	Weight kg (lbs)	Part Number
<b>Controller</b>		
Turbo-V 81-AG Rack controller*	1.7 (3.2)	9698988
Turbo-V 81-AG with RS-232/485		9698989
Turbo-V 81-AG with Profibus		9698990

\* Order power cable separately

#### Accessories

Air cooling kit (0.5 m cable)	9699290
Air cooling kit extension cable (5 m)	9699940
Vent valve N.O. 0.5 mm orifice (0.5 m cable)	9699844
Vent valve N.C. 0.5 mm orifice (0.5 m cable)	9699844M001
Vent valve extension cable (5 m)	9699941
Mains cable NEMA plug (3 m)	9699958
Mains cable european plug (3 m)	9699957
Pump extension cable (3 m)	9699942
Rack adapter for controller	9699191

#### Active Gauges

FRG-700 Pirani/IMG Combination Gauge, KF25	FRG700KF25
FRG-700 Pirani/IMG Combination Gauge, DN40 CF	FRG700CF35
FRG-702 Pirani/IMG Combination Gauge, KF25 All metal - bakeable	FRG702KF25
FRG-702 Pirani/IMG Combination Gauge, DN40 CF All metal - bakeable	FRG702CF35
Gauge connection cable to AG rack controller - 3 m	9699960
Gauge connection cable to AG rack controller - 5 m	9699961

# AGILENT TURBO PUMP MODELS

## ▶ Agilent TwisTorr 304 FS

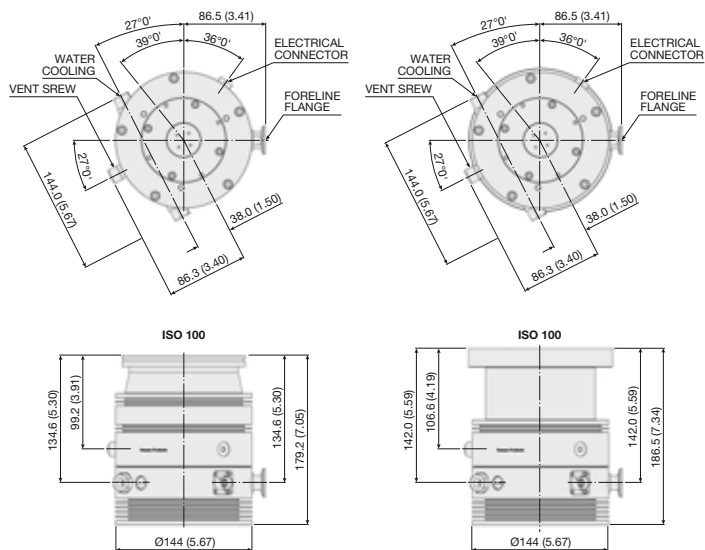

Dimensions: millimeters (inches)

### Technical Specifications

<b>Pumping speed (l/s)</b>				
With CFF 6" or ISO 100:	N <sub>2</sub> : 250 l/s	He: 255 l/s	H <sub>2</sub> : 220 l/s	Ar: 250 l/s
With CFF 8" or ISO 160:	N <sub>2</sub> : 280 l/s	He: 255 l/s	H <sub>2</sub> : 220 l/s	Ar: 250 l/s
<b>Gas throughput at full rotational speed (with recommended forepump)</b>				
Ambient Temp. (25 °C)		N <sub>2</sub> : 170 sccm	Ar: 110 sccm	
Water Temp. (25 °C, 50 l/h)		N <sub>2</sub> : 170 sccm	Ar: 110 sccm	
<b>Compression ratio &amp; Foreline tolerance</b>	N <sub>2</sub> : > 1 x 10 <sup>11</sup> N <sub>2</sub> : >10 mbar	He: > 1 x 10 <sup>8</sup> He: >10 mbar	H <sub>2</sub> : 1.5 x 10 <sup>6</sup> H <sub>2</sub> : >4 mbar	Ar: > 1 x 10 <sup>11</sup> Ar: >10 mbar
<b>Base pressure with recommended forepump (5 m<sup>3</sup>/h)</b>	< 1 x 10 <sup>-10</sup> mbar (< 1 x 10 <sup>-10</sup> Torr)			
<b>Inlet flange</b>	CFF 8" O.D.		ISO 160	
	CFF 6" O.D.		ISO 100	
<b>Foreline flange</b>	KF16 NW (KF25 - optional)			
<b>Rotational speed</b>	60000 rpm (1010 Hz driving frequency)			
<b>Start-up time</b>	< 3 minutes			
<b>Recommended forepump</b>	Mechanical: Agilent DS 102 Dry pump: Agilent SH-110			
<b>Operating position</b>	Any			
<b>Operating ambient temperature</b>	+5 °C to +35 °C			
<b>Relative humidity of air</b>	0 - 90 % (not condensing)			
<b>Bakeout temperature</b>	80 °C at inlet flange max. (ISO flange) 120 °C at inlet flange max. (CF flange)			
<b>Lubricant</b>	Permanent lubrication			
<b>Cooling requirements</b>	Forced air (5- 35 °C ambient temperature) Water (mandatory if ambient temperature > 35 °C)			
<b>Coolant water</b>	Minimum flow: 50 l/h (0.89 GPM)	Temperature: +15 °C to +30 °C	Pressure: 3 to 5 bar (45 to 75 psi)	
<b>Noise pressure level</b>	< 50 dB(A) at 1 meter			
<b>Storage temperature</b>	-40 °C to +70 °C			
<b>Max altitude</b>	3000 m			
<b>Weight kg (lbs)</b>	Pump ISO 100: 5.5 kg (12.3)	Pump CFF 6": 7.5 kg (16.5)	Pump ISO 160: 5.7 kg (12.6)	Pump CFF 8": 9.7 kg (20.9)



# TURBO PUMPS

**Pumping Speed vs Inlet Pressure**

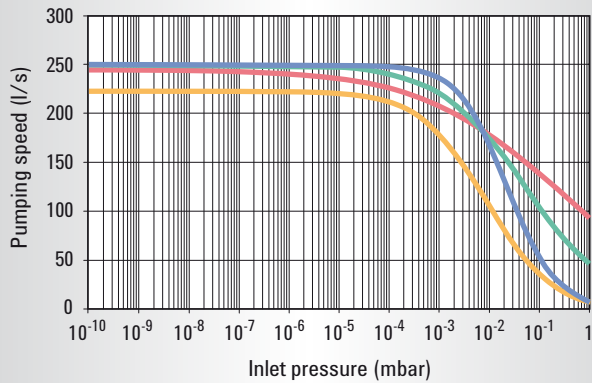

— Argon — Nitrogen — Helium — Hydrogen

**Compression Ratio vs Foreline Pressure**

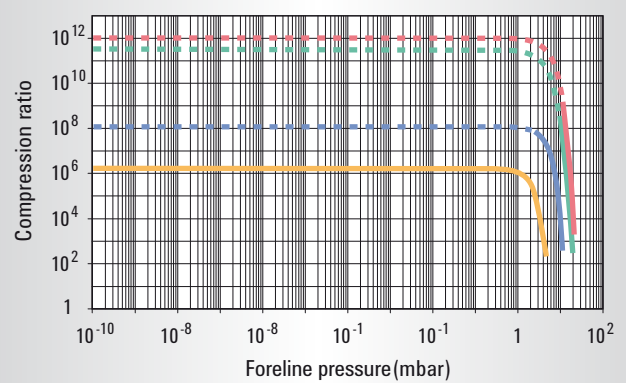

— Argon — Nitrogen — Helium — Hydrogen

## Ordering Information

Pumps		Part Numbers
TwisTorr 304 FS ISO100	w/ water cooling	X3500-64000
TwisTorr 304 FS CFF 6"	w/ water cooling	X3500-64001
TwisTorr 304 FS ISO160	w/ water cooling	X3500-64002
TwisTorr 304 FS CFF 8"	w/ water cooling	X3500-64003
TwisTorr 304 FS ISO100	w/o water cooling	X3500-64004
TwisTorr 304 FS CFF 6"	w/o water cooling	X3500-64005
TwisTorr 304 FS ISO160	w/o water cooling	X3500-64006
TwisTorr 304 FS CFF 8"	w/o water cooling	X3500-64007
TwisTorr 304 FS ISO100 SF	w/ water cooling	X3500-64010

Controllers	Part Numbers
TwisTorr 304 FS on board controller 24 Vdc	X3507-64002
TwisTorr 304 FS on board controller 100-240 Vac	X3507-64003
TwisTorr 304 FS AG Rack controller with RS 232/485	X3506-64002
TwisTorr 304 FS AG Rack controller with Profibus	X3506-64003

Accessories	Part Numbers
Mains cable NEMA plug, 3 m long	9699958
Mains cable European plug, 3 m long	9699957
Serial cable and T-plus Software	9699883
Inlet Screen ISO100	X3500-68000
Inlet Screen CFF 6"	9699302
Inlet Screen ISO160	X3500-68001
Inlet Screen CFF 8"	9699304
Water cooling kit	9699337

Accessories	Part Numbers
Plastic water cooling kit	9699347
Air cooling kit for on board controller	X3500-68010
Fan extension cable for on board controller	9699949
Air cooling kit for rack AG controller	X3500-68011
Fan extension cable for rack AG controller	9699940
Bracket for on board controller side mounting	X3500-68012
Vibration isolator ISO 100	9699344
Vibration isolator CFF 6"	9699334
Vibration isolator ISO 160	9699345
Vibration isolator CFF 8"	9699335
Vibration isolator ISO 100 IDX	9699396
Vent flange, NW 10 KF / M8	9699108
Delay vent valve 1.2 mm orifice	X3505-68000
Delay vent valve 0.5 mm orifice	X3505-68001
Vent valve N.O. for rack AG controller (0.5 mm)	9699844
Vent valve for on-board controller (1.2 mm)	9699834
Vent valve for on-board controller (0.5 mm)	9699834M006
Purge valve 10 SCCM NW16KF - M12	9699239
Purge valve 10 SCCM ¼ Swagelok - M12	9699240
Purge valve 20 SCCM NW16KF - M12	9699241
Purge valve 20 SCCM ¼ Swagelok - M12	9699242
Purge valve 10 SCCM ¼ Swagelok - ¼ Swagelok	9699232
Purge valve 20 SCCM ¼ Swagelok - ¼ Swagelok	9699236
TwisTorr 304 foreline flange KF25	X3500-68002
Active Gauges	See TwisTorr 304 FS AG Rack controller (page 29)

# AGILENT TURBO PUMP CONTROLLERS

## ▶ Agilent TwisTorr 304 FS on board Controller



120/220 V controller front panel

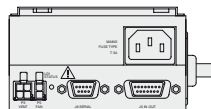

24 V controller front panel

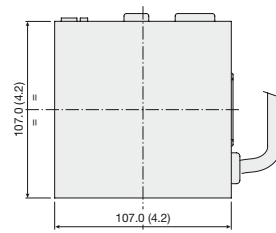
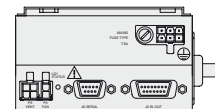

Dimensions: millimeters (inches)

The TwisTorr 304 FS on board controllers are microprocessor-controlled frequency converters, fully controllable through PC software, with self-diagnostic and protection features that ensure the highest degree of reliability.

They can be mounted on board, either on the bottom or on the side of the pump, offering outstanding flexibility and simplicity.

### Technical Specifications

<b>Input voltages:</b>	
On board controller, 24 Vdc	24 Vdc $\pm$ 10%
On board controller, 120/220 Vac	100/120/220/240 Volt, 1 phase, 50/60 Hz
<b>Maximum input power:</b>	
100-240 controller, 24 Vdc	200 W
100-240 controller, 120/220 Vac	300 VA
<b>Output voltage</b>	75 Vac, 3 phase
<b>Output frequency</b>	963 Hz
<b>Nominal power</b>	150 W
<b>Start-up power</b>	150 W
<b>Operating temperature</b>	0 °C to +40 °C
<b>Storage temperature</b>	20 °C to +70 °C

### Ordering Information

Description	Weight kg (lbs)	Part Number
<b>Controllers</b>		
TwisTorr 304 FS on board controller*, 24 Vdc	0.3 (0.66)	X3507-64002
TwisTorr 304 FS on board controller*, 100-240 Vac	0.3 (0.66)	X3507-64003
<i>* Order power cable separately</i>		
<b>Accessories</b>		
Mains cable NEMA plug, 3 m long		9699958
Mains cable European plug, 3 m long		9699957
Serial cable and T-plus Software		9699883
Air cooling kit		X3500-68010
Fan extension cable		9699949
Bracket side mounting		X3500-68012
Vent valve (1.2 mm)		9699834
Vent valve (0.5 mm)		9699834M006

## ▶ Agilent TwisTorr 304 FS AG Rack Controller

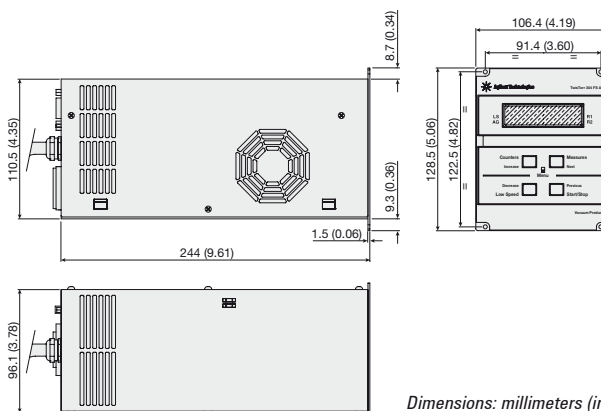

Dimensions: millimeters (inches)

The TwisTorr 304 FS AG Rack controller is a microprocessor-controlled frequency converter with new, enhanced features that allow greater control and communication capabilities. This compact, ¼ rack unit is designed for full worldwide compatibility, for vent valve control, active gauge pressure reading and pump operation parameters control, as well as for self diagnostic and protection features.

### • Universal Voltage

Controller able to auto set according to the input voltage, providing flexibility for easy installation worldwide

### • RS-232/485 Communication Protocols and Profibus (Options)

- Allows the pump to be interfaced with the system controls
- Enables the pump to be operated via PC with T-Plus software
- Helps development of own customer software

### • Stop Speed Reading (SSR)

- Continues pump speed reading after the stop command.
- Allows monitoring the pump in slow down ramp and shut down time

### • N.O. and N.C. Vent Valve Drive

- Valve delay and opening time adjustable
- Vent valve driven by controller automatically or by serial line
- Opening time control through SSR function

## Technical Specifications

<b>Input</b>	100 ÷ 240 Vac 50/60 Hz
<b>Maximum input power</b>	300 VA
<b>Output voltage</b>	75 Vac
<b>Output frequency</b>	963 Hz
<b>Nominal output power</b>	150 W
<b>Operating temperature</b>	+5 °C to +45 °C
<b>Storage temperature</b>	-20 °C to +70 °C

### • Active Gauge Pressure Reading Capability

- Able to operate with Active Gauges (IM-500, Full Range Gauge FRG-700 and FRG-702)
- Provides accurate pressure measurements from atm down to 10<sup>-9</sup> mbar
- Rack mounted control electronics no longer necessary, with simple +24 Vdc power connector
- Proven inverted magnetron design
- Rapid start even in high-vacuum conditions

## Ordering Information

Description	Weight kg (lbs)	Part Number
<b>Controller</b>		
TwisTorr 304 FS AG Rack controller* with RS232/485	1.7 (3.2)	X3506-64002
TwisTorr 304 FS AG Rack controller* with Profibus	1.7 (3.2)	X3506-64003

\* Order power cable separately

### Accessories

Mains cable NEMA plug, 3 m long	9699958
Mains cable European plug, 3 m long	9699957
Serial cable and T-plus Software	9699883
Air cooling kit	X3500-68011
Fan extension cable	9699940
Vent valve N.O. (0.5 mm)	9699844

### Active Gauges

PVG-500 Pirani, KF16	PVG500KF16
PVG-500 Pirani Tungsten filament, KF16	PVG500KF16S
FRG-700 Pirani/IMG Combination Gauge, KF25	FRG700KF25
FRG-700 Pirani/IMG Combination Gauge, DN40 CF	FRG700CF35
FRG-702 Pirani/IMG Combination Gauge, KF25 All metal - bakeable	FRG702KF25
FRG-702 Pirani/IMG Combination Gauge, DN40 CF All metal - bakeable	FRG702CF35
PCG-750 Pirani/CDG Combination Gauge (Tungsten), KF16	PCG750KF16
Gauge connection cable to AG rack controller - 3 m	9699960
Gauge connection cable to AG rack controller - 5 m	9699961



# AGILENT TURBO PUMP MODELS

## ▶ Agilent Turbo-V 551 Navigator

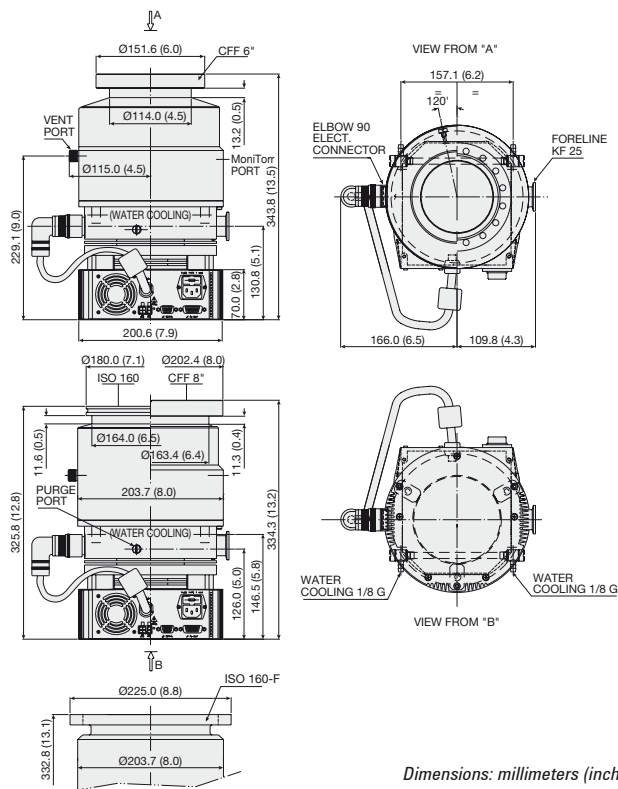

Dimensions: millimeters (inches)

### Technical Specifications

<b>Pumping speed</b> (with inlet screen)			
CFF 6":	N <sub>2</sub> : 350 l/s	He: 450 l/s	H <sub>2</sub> : 450 l/s
CFF 8" or ISO 160:	N <sub>2</sub> : 550 l/s	He: 600 l/s	H <sub>2</sub> : 510 l/s
<b>Compression ratio</b>	N <sub>2</sub> : 1 x 10 <sup>9</sup>	He: 1 x 10 <sup>7</sup>	H <sub>2</sub> : 1 x 10 <sup>6</sup>
<b>Base pressure*</b> (with minimum recommended forepump)	<1 x 10 <sup>-10</sup> mbar (< 1 x 10 <sup>-10</sup> Torr)		
<b>Inlet flange</b>	CFF 6"	ISO 160	
	CFF 8"	ISO 160-F bolted	
<b>Foreline flange</b>			KF 25
<b>Rotational speed</b>		42,000 rpm	
<b>Start-up time</b>		<5 minutes	
<b>Recommended forepump</b>		Mechanical: Agilent DS 302 Dry scroll: Agilent TS300, IDP-15	
<b>Operating position</b>		Any	
<b>Cooling requirements</b>		Natural air convection Water optional (use water with electrical conductivity ≤ 500 µS/cm)	
<b>Bakeout temperature</b>		120 °C at inlet flange max. (CF flange) 80 °C at inlet flange max. (ISO flange)	
<b>Vibration level</b> (displacement)		<0.01 µm at inlet flange	
<b>Weight</b> kg (lbs)		ISO flange 19.4 (43.0) CF flange 23.4 (51.6) CF and ISO bolted flange 23.4 (51.6)	

\* According to PNEUROP 5608.

SEM version available on request

# TURBO PUMPS

**Pumping Speed vs Inlet Pressure (DN 160 only)**

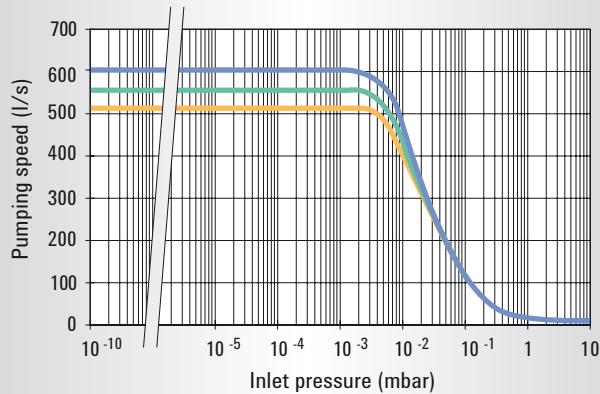

— Nitrogen — Helium — Hydrogen

**Compression Ratio vs Foreline Pressure**

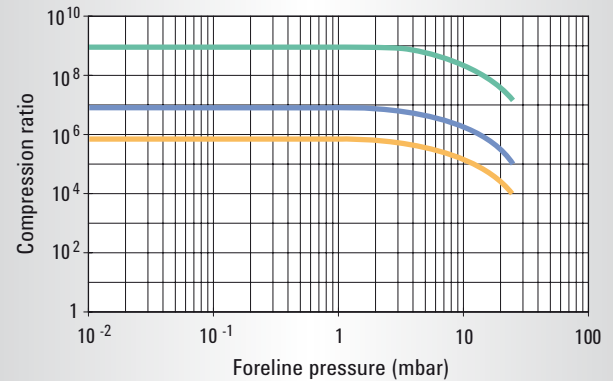

— Nitrogen — Helium — Hydrogen

## Ordering Information

Description	Weight kg (lbs)	Part Number
<b>Complete Systems</b>		
Turbo-V 551 Navigator complete system, ISO 160 flange	19.4 (43.0)	9698832
Turbo-V 551 Navigator complete system, ISO 160-F bolted flange	23.4 (51.6)	9698842
Turbo-V 551 Navigator complete system, 6" CF flange	23.4 (51.6)	9698835
Turbo-V 551 Navigator complete system, 8" CF flange	23.4 (51.6)	9698833
<i>Complete system includes: Pump, Inlet screen, Controller mounted on the bottom, 2 Mains cables (NEMA plug and European plug).</i>		
<b>Pumps</b>		
Turbo-V 551 Navigator pump, ISO 160 flange	16.0 (35.0)	9698922
Turbo-V 551 Navigator pump, ISO 160-F bolted flange	22.0 (49.0)	9698944
Turbo-V 551 Navigator pump, 6" CF flange	22.0 (49.0)	9698925
Turbo-V 551 Navigator pump, 8" CF flange	22.0 (49.0)	9698923
<b>Controllers</b>		
Turbo-V 551 Navigator controller 120/220 V - 50/60 Hz	3.0 (6.0)	9698976
Turbo-V 551 Rack controller, 100-240 V	15.7 (35.0)	X3501-64001

Description	Weight kg (lbs)	Part Number
<b>Accessories</b>		
Mains cable NEMA plug, 3 m long		9699958
Mains cable European plug, 3 m long		9699957
Serial cable and T-plus Software <i>(previous release Navigator 2.2 included in the CD)</i>		9699883
Inlet screen DN 100		9699302
Inlet screen DN 160		9699304
Water cooling kit		9699337
Plastic water cooling kit		9699347
Air cooling kit for use with Navigator controller		9699339
Air cooling kit for use with standard rack controller, 24 V		X3501-68001
Bracket for Navigator controller side mouting		9699349
Vibration damper CFF 6"	3.0 (7.0)	9699334
Vibration damper ISO 160	4.0 (9.0)	9699345
Vibration damper CFF 8"	4.0 (9.0)	9699335
Vent flange, NW 10 KF / M8		9699108
Vent valve kit for standard rack controller, 24 V		X3501-68002
Vent valve for Navigator controller		9699834
Purge valve 10 SCCM NW16KF - M12		9699239
Purge valve 10 SCCM ¼ Swagelok - M12		9699240

# AGILENT TURBO PUMP MODELS

## ▶ Agilent Turbo-V 701 Navigator

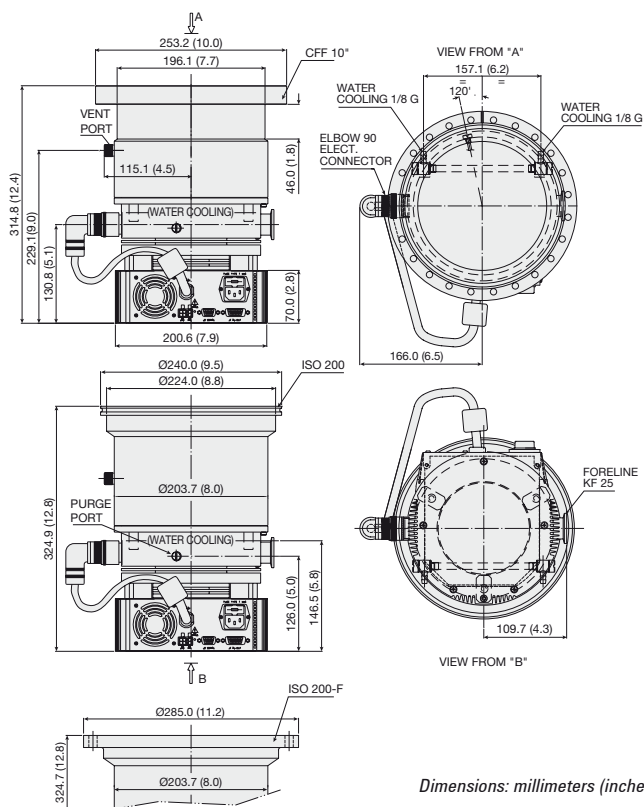

Dimensions: millimeters (inches)

### Technical Specifications

<b>Pumping speed</b> (with inlet screen) CFF 10" or ISO 200:	N <sub>2</sub> : 690 l/s	He: 620 l/s	H <sub>2</sub> : 510 l/s
<b>Compression ratio</b>	N <sub>2</sub> : 1 x 10 <sup>9</sup>	He: 1 x 10 <sup>7</sup>	H <sub>2</sub> : 1 x 10 <sup>6</sup>
<b>Base pressure*</b> (with minimum recommended forepump)	<1 x 10 <sup>-10</sup> mbar (< 1 x 10 <sup>-10</sup> Torr)		
<b>Inlet flange</b>	CFF 10"	ISO 200	ISO 200-F bolted
<b>Foreline flange</b>	KF 25		
<b>Rotational speed</b>	42,000 rpm		
<b>Start-up time</b>	<5 minutes		
<b>Recommended forepump</b>	Mechanical: Agilent DS 402 Dry scroll: Agilent TS300, IDP-15		
<b>Operating position</b>	Any		
<b>Cooling requirements</b>	Natural air convection Water optional (use water with electrical conductivity ≤ 500 μS/cm)		
<b>Bakeout temperature</b>	120 °C at inlet flange max. (CF flange) 80 °C at inlet flange max. (ISO flange)		
<b>Vibration level</b> (displacement)	<0.01 μm at inlet flange		
<b>Weight</b> kg (lbs)	ISO flange 19.4 (43.0) CF flange 25.5 (54.2) CF and ISO bolted flange 25.5 (54.2)		

\* According to PNEUROP 5608.

SEM version available on request

# TURBO PUMPS

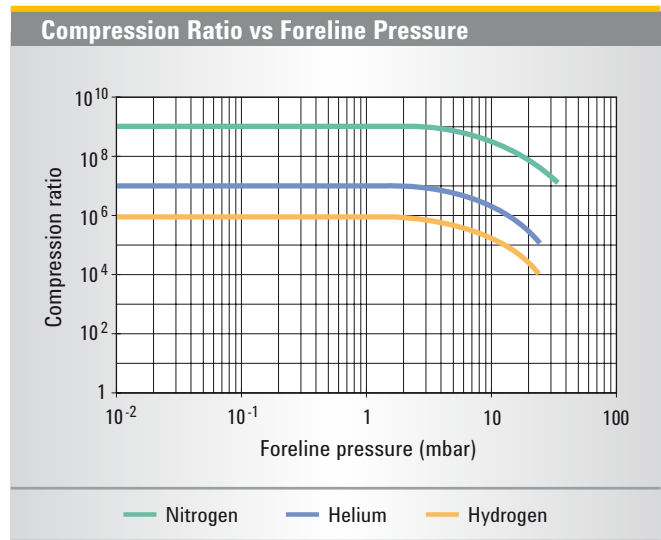
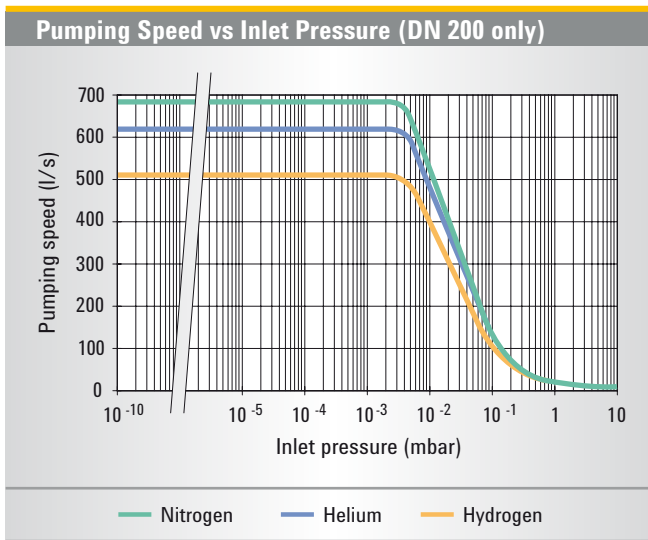

## Ordering Information

Description	Weight kg (lbs)	Part Number
<b>Complete Systems</b>		
Turbo-V 701 Navigator complete system, ISO 200 flange	19.0 (43.0)	9698836
Turbo-V 701 Navigator complete system, ISO 200-F bolted flange	25.0 (56.0)	9698843
Turbo-V 701 Navigator complete system, 10" CF flange	25.0 (56.0)	9698837
<i>Complete system includes: Pump, Inlet screen, Controller mounted on the bottom, 2 Mains cables (NEMA plug and European plug).</i>		
<b>Pumps</b>		
Turbo-V 701 Navigator pump, ISO 200	16.0 (35.0)	9698926
Turbo-V 701 Navigator pump, ISO 200-F bolted	22.0 (49.0)	9698945
Turbo-V 701 Navigator pump, 10" CFF	22.0 (49.0)	9698927
<b>Controllers</b>		
Turbo-V 701 Navigator controller 120/220 V - 50/60 Hz	3.0 (6.0)	9698977
Turbo-V 701 Rack controller, 100-240 V	16.0 (35.0)	X3501-64002
<b>Accessories</b>		
Mains cable NEMA plug, 3 m long		9699958
Mains cable European plug, 3 m long		9699957
Serial cable and T-plus Software ( <i>previous release Navigator 2.2 included in the CD</i> )		9699883
Inlet screen DN 200		9699316
Water cooling kit		9699337
Plastic water cooling kit		9699347
Air cooling kit for use with Navigator controller		9699339
Air cooling kit for use with standard rack controller, 24 V		X3501-68001
Bracket for Navigator controller side mounting		9699349
Vibration damper, ISO 200	5.0 (10.0)	9699346
Vibration damper, CFF 10"	5.0 (10.0)	9699336
Vent flange, NW 10 KF / M8		9699108
Vent valve kit for standard rack controller		X3501-68002
Vent valve for Navigator controller		9699834
Purge valve 10 SCCM NW16KF – M12		9699239
Purge valve 10 SCCM ¼ Swagelok – M12		9699240



# AGILENT TURBO PUMP CONTROLLERS

## ▶ Agilent Turbo-V 551 and 701 Navigator Controllers

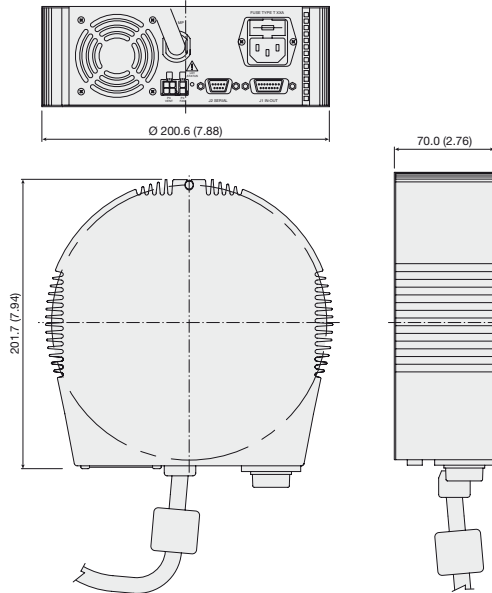

Dimensions: millimeters (inches)

The Turbo-V 551 and 701 Navigator controllers are microprocessor-controlled frequency converters, fully controllable through PC software, with self-diagnostic and protection features that ensure the highest degree of reliability. They can be mounted on board, either on the bottom or on the side of the pump, offering outstanding flexibility and simplicity.

### Technical Specifications

<b>Input voltages</b>	100/120/220/240 VAC 50/60 Hz, 1 ph
<b>Maximum input power</b>	640 VA
<b>Output voltage</b>	54 VAC, 3 ph
<b>Output frequency</b>	714 Hz
<b>Operating temperature</b>	0 °C to +40 °C
<b>Storage temperature</b>	-20 °C to +70 °C

### Ordering Information

Description	Weight kg (lbs)	Part Number
<b>Controllers</b>		
Turbo-V551 Navigator controller 120/220 V - 50/60 Hz	3.0 (6.0)	9698976
Turbo-V701 Navigator controller 120/220 V - 50/60 Hz	3.0 (6.0)	9698977
<b>Accessories</b>		
Mains cable NEMA plug, 3 m long		9699958
Mains cable European plug, 3 m long		9699957
Serial cable and T-plus Software <i>(previous release Navigator 2.2 included in the CD)</i>		9699883
External "TMP Profibus gateway"		9699261

# TURBO PUMPS

## ▶ Agilent Turbo-V 551 and 701 Rack Controllers

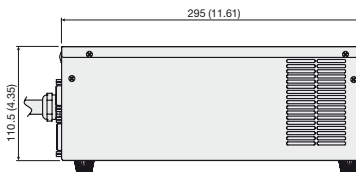
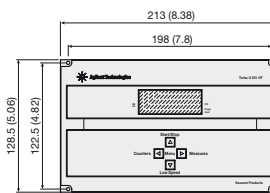

Dimensions: millimeters (inches)

These controllers are microprocessor-controlled frequency converters with self diagnostic and protection features that ensure the highest degree of reliability. The compact, ½ rack unit has a multifunction alphanumeric display for pump status and error code diagnostics. The front panel has a two-line dot matrix LCD display with back lighting. It displays rotational speed as the pump starts up and indicates when full speed is reached. At any time during the operation of the pump, the speed, current, power, and bearing temperature can be displayed. Additionally, the microprocessor acts as a pump

cycle log, and can display the number of vacuum cycles, the cycle time for the current cycle, and the total operating hours on the pump. Remote operation can be accomplished with logic level contact closures and with optional computer interfaces.

PCB controllers are available. Please contact Agilent for details.

### Technical Specifications

<b>Input voltages</b>	100-240 V 1 ph, 50/60 Hz
<b>Maximum input power</b>	800 VA
<b>Output frequency</b>	700 Hz
<b>Maximum output power*</b>	
V 501:	320 W
V 701:	350 W
<b>Startup power</b>	430 W
<b>Operating temperature</b>	+5 °C to +45 °C
<b>Storage temperature</b>	-20 °C to +70 °C

\* Data valid for nitrogen.

### Ordering Information

Description	Weight kg (lbs)	Part Number
<b>Controllers</b>		
Turbo-V 551 Rack controller with RS 232/485, 120-220 V	15.7 (35.0)	X3501-64001
Turbo-V 701 Rack controller with RS 232/485, 120-220 V	15.7 (35.0)	X3501-64002
<b>Accessories</b>		
J1 input mating connector		9699853
P6 and P7 mating plug		9699854
Mains cable (European plug, 3 m long)		9699957
Mains cable (American plug, 120 V, 3 m long)		9699958
<b>Options</b>		
P2 output mating connector		9699852
Rack adapter for controller		9699191
Controller to pump extension cable (3 m extension) for Turbo-V 551, 701	1.0 (2.0)	9699948
Controller to pump extension cable (5 m extension) for Turbo-V 551, 701	2.0 (4.0)	9699948M001
Controller to pump extension cable (20 m extension) for Turbo-V 551, 701	4.0 (8.0)	9699948M002

# AGILENT TURBO PUMP MODELS

## ▶ Agilent Turbo-V 750 TwisTorr System

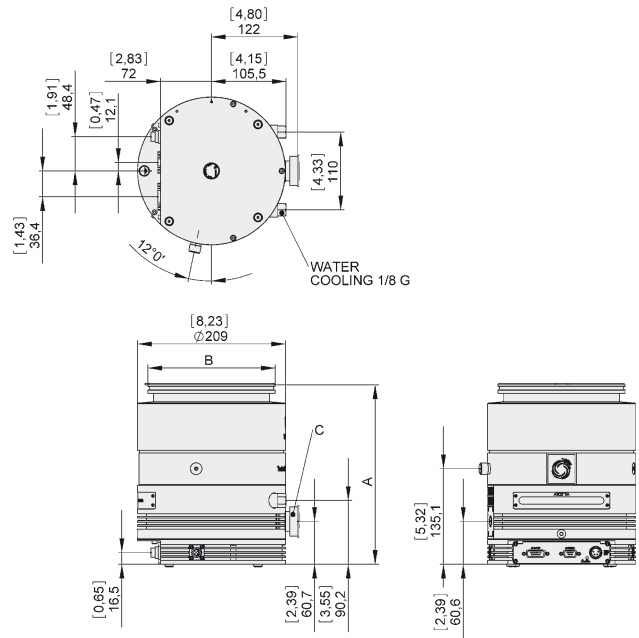

Dimensions: millimeters (inches)

### Technical Specifications

Vacuum Performances	
Pumping speed for N <sub>2</sub> (*)	N <sub>2</sub> = 700 l/s
Pumping speed for Ar (*)	Ar = 680 l/s
Pumping speed for He (*)	He = 680 l/s
Pumping speed for H <sub>2</sub> (*)	H <sub>2</sub> = 580 l/s
Compression ratio for N <sub>2</sub>	N <sub>2</sub> = 1 x 10 <sup>11</sup>
Compression ratio for Ar	Ar > 1 x 10 <sup>11</sup>
Compression ratio for He	He = 2 x 10 <sup>8</sup>
Compression ratio for H <sub>2</sub>	H <sub>2</sub> = 2.5 x 10 <sup>6</sup>
Base pressure*	<1 x 10 <sup>-10</sup> mbar
<i>(with minimum recommended forepump)</i>	
Max foreline pressure for N <sub>2</sub>	6 mbar
Inlet Flange size	ISO 160K, CFF 8", ISO 160F
Foreline flange	KF25
Other	
Rotational speed	Selectable from 350 Hz to 825 Hz
Start up time (90% of full speed)	< 3 min
Recommended forepump	PTS300, DS302, IDP-15
Operational position	Any
Cooling options	Forced Air (up to 35 °C ambient temp.) Water (corrosion resistant loop)
Max flange temperature during bake-out (no gas flow)	120 °C (CFF), 80 °C (ISO)
Noise level (pump at full speed, no load)	FAN off < 52 dB(A) at 1 meter FAN on < 55 dB(A) at 1 meter
Storage temperature	-20 °C to +70 °C
Certifications	CE, C, CSA_US, ROHS compliant
Purge and Vent	Standard Purge & Vent ports Automated Purge/Vent device (accessory)
Weight (with integrated controller)	ISO 160 K = 15.9 kg (34.9 lbs) CFF 8" = 22.5 kg (49.4 lbs)

(\*): According to Pneuop 5608 III, TS 300 PRIMARY PUMP, NO INLET SCREEN

Model	Inlet Flange	A	B	C
9698813	ISO 160K	253.8 (9.99)	Ø 179.9 (7.08)	KF 25
9698814	CFF 8"	264.2 (10.40)	Ø 202.4 (7.97)	KF 25
9698818	ISO 160F	262.7 (10.34)	Ø 225 (8.86)	KF 25

### Controller Specifications

Controller type	Fully integrated electronics
Motor control mode	Field Oriented Control (FOC)
Input voltage	48 Vdc (± 10%)
Maximum input power	450 W
Maximum output power	400 W (pump ramp-up) 300 W (water cooling) 200 W (forced air cooling)
Input voltage for power supply	100 – 240 Vac (± 10%)
Input frequency for power supply	50 – 60 Hz
Maximum input power for power supply	550 VA
Maximum operating power for power supply	450 W
Interface	Navigator standard remote I/O RS 232, RS 485 serial Can accept Profibus external device
Protection category	IP 54
Data Logger	Standard
Stop speed reading	Standard
Automated Purge/Vent device control	Standard
Leak Detector Mode function	Standard

# TURBO PUMPS

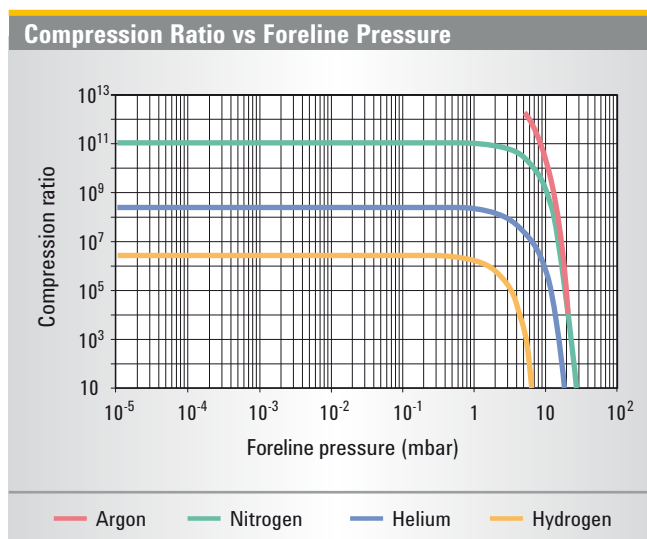
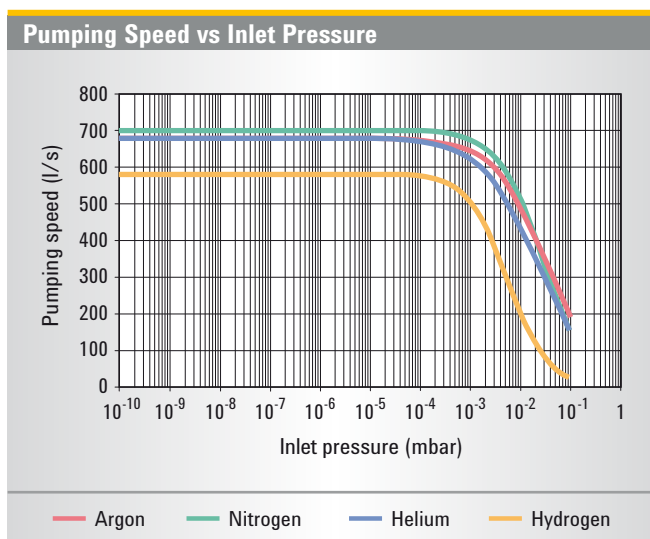

## Ordering Information

Pumping Systems*	Part Number
Agilent Turbo-V 750 ISO 160K On-Board	9698813
Agilent Turbo-V 750 CFF 8" On-Board	9698814
Agilent Turbo-V 750 ISO 160F On-Board	9698818

(\*): Pumping Systems include pump with integrated controller 48 Vdc, inlet screen, 9 and 15 pin mating connectors IP-54.

### Accessories

Turbo-V 750/850 TwisTorr Power Supply (5 m pump cable)*	9696521
Mains cable NEMA Plug, 3 m long	9699958
Mains cable European Plug, 3 m long	9699957
Turbo-V 750/850 TwisTorr Purge/Vent Device N.C. (0.2 m cable)	9696502
Turbo-V 750/850 TwisTorr Fan (0.2 m cable)	9696503
T-Plus software and serial cable	9699883
Inlet screen ISO 160 and CFF 8"	9699304
Water cooling kit (plastic model)	9699347
Water cooling kit (metallic model)	9699337
Water kit, Hose tail 1/8G	9699828
Vibration isolator, ISO 160	9699345
Vibration isolator, CFF 8"	9699335
Vent flange, NW 10 KF / M8	9699108
Purge valve with KF16-M12 10 SCCM	9699239
Purge valve with 7/16-M12 10 SCCM	9699240
Purge valve KF16-M12 20 SCCM	9699241
Purge valve 7/16-M12 20 SCCM	9699242
External Profibus TMP gateway	9699261
Forepump DS 302, with 1 ph., universal motor	9499325
TriScroll Dry Vacuum Pump PTS 300 single phase, US cord	PTS03001UNIV
TriScroll Dry Vacuum Pump PTS 300 single phase, Euro cord	PTS03001UNIVEU
TriScroll Dry Vacuum Pump PTS 300 single phase, UK cord	PTS03001UNIVUK
TriScroll Dry Vacuum Pump PTS 300 3 phase	PTS03003UNIV
IDP-15 Dry Scroll Pump, Std	X3815-64000
IDP-15 Dry Scroll Pump, Std with inlet valve	X3815-64010

(\*) Power Supply is necessary to provide 48 VDC to the on board electronics.



# AGILENT TURBO PUMP MODELS

## ▶ Agilent Turbo-V 750 TwisTorr Rack

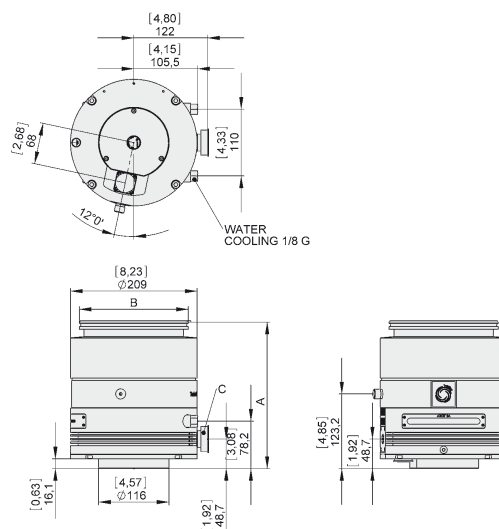

Model	Inlet Flange	A	B	C
9696013	ISO 160K	241.8 (9.52)	Ø 179.9 (7.08)	KF 25
9696014	CFF 8"	252.2 (9.93)	Ø 202.4 (7.97)	KF 25
9696017	CFF 6"	258.7 (10.19)	Ø 151.6 (5.97)	KF 25
9696018	ISO 160F	252.7 (9.95)	Ø 225 (8.86)	KF 25

### Technical Specifications

Vacuum Performances	ISO 160/CFF 8"	CFF 6"
Pumping speed for N <sub>2</sub> (*)	N <sub>2</sub> = 700 l/s	N <sub>2</sub> = 370 l/s
Pumping speed for Ar (*)	Ar = 680 l/s	Ar = 340 l/s
Pumping speed for He (*)	He = 680 l/s	He = 500 l/s
Pumping speed for H <sub>2</sub> (*)	H <sub>2</sub> = 580 l/s	H <sub>2</sub> = 470 l/s
Compression ratio for N <sub>2</sub>	N <sub>2</sub> = 1 x 10 <sup>11</sup>	
Compression ratio for Ar	Ar > 1 x 10 <sup>11</sup>	
Compression ratio for He	He = 2 x 10 <sup>8</sup>	
Compression ratio for H <sub>2</sub>	H <sub>2</sub> = 2.5 x 10 <sup>6</sup>	
Base pressure* (with minimum recommended forepump)	<1 x 10 <sup>-10</sup> mbar	
Max foreline pressure for N <sub>2</sub>	6 mbar	
Inlet Flange size	ISO 160K, CFF 8", ISO 160F	
Foreline flange	KF25	
<b>Other</b>		
Rotational speed	Selectable from 350 Hz to 825 Hz	
Start up time (90% of full speed)	< 6 min (with 5 m pump cable length)	
Recommended forepump	PTS300, DS302, IDP-15	
Operational position	Any	
Cooling options	Forced Air (up to 35 °C ambient temp.) Water (corrosion resistant loop)	
Max flange temperature during bake-out (no gas flow)	120 °C (CFF), 80 °C (ISO)	
Noise level (pump at full speed, no load)	FAN off < 52 dB(A) at 1 meter FAN on < 55 dB(A) at 1 meter	
Storage temperature	-20 °C to +70 °C	
Certifications	CE, C, CSA, US, ROHS compliant	
Purge and Vent	Standard Purge & Vent ports Automated Purge/Vent device (accessory)	
Weight	ISO 160 K = 15.7 kg (34.6 lbs) CFF 8" = 22.3 kg (49.2 lbs)	

(\*): According to Pneuport 5608 III, TS 300 PRIMARY PUMP, NO INLET SCREEN

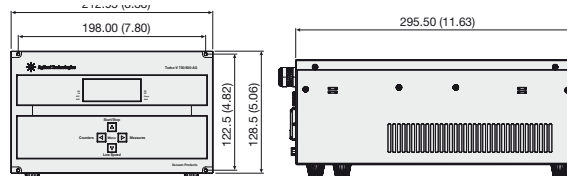

Dimensions: millimeters (inches)

Controller Specifications	Controller Models 9699525-9699526	Controller Model X3501-64000
Input voltage	100 – 240 Vac (± 10%)	100 – 240 Vac (± 10%)
Input frequency	50 – 60 Hz	50 – 60 Hz
Maximum input power	600 VA	800 VA
Maximum output power		
pump ramp-up	320 W	420 W
water cooling	300 W	300 W
forced air cooling	200 W	200 W
<i>(Specification with standard cable length 5 mt)</i>		
Interface	Navigator standard remote I/O RS 232, RS 485 serial Can accept Internal Profibus board	Navigator standard remote I/O RS 232
Protection category	IP 20	IP 20
Data Logger	Standard	No
Stop speed reading	Standard	Yes
Active stop	Standard	Yes
Automated Purge/Vent device control	Standard	Yes
External gauge readout	2 ports compatible with Agilent gauges	No
Primary pump control	Pilot 2 external configurable relays (48 Vdc (± 10%) - 250 mA MAX)	Yes

# TURBO PUMPS

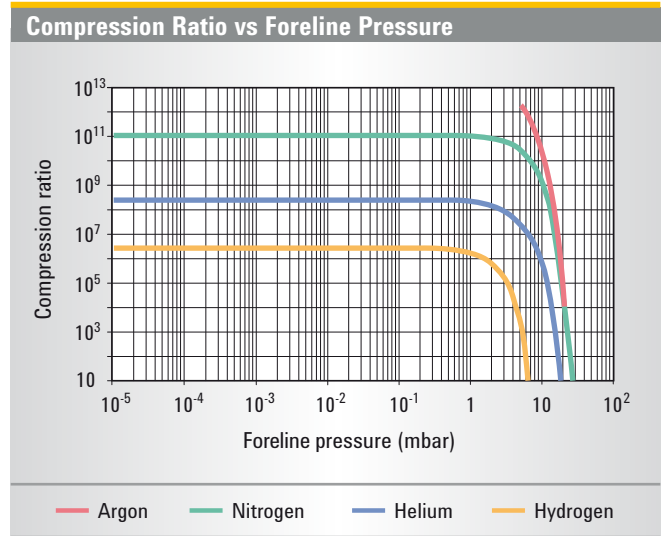
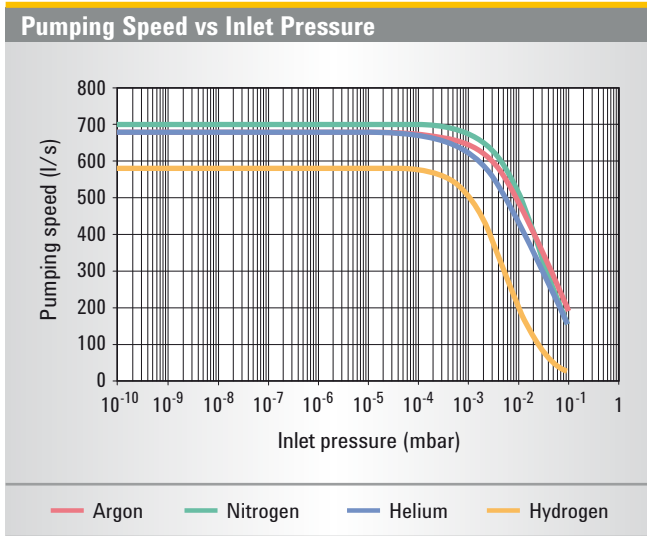

## Ordering Information

Pumps	Part Number
Agilent Turbo-V 750 ISO 160K Rack	9696013
Agilent Turbo-V 750 CFF 8" Rack	9696014
Agilent Turbo-V 750 CFF 6" Rack	9696017
Agilent Turbo-V 750 ISO 160F Rack	9696018

Controllers	Part Number
Agilent Turbo-V 750/850-AG Rack CNT (5 m pump cable incl. - max TMP cable 25 m)	9699525
Agilent Turbo-V 750/850-AG Rack CNT Profibus (5 m pump cable incl. - max TMP cable 25 m)	9699526
Agilent Turbo-V 750/850-AG Rack CNT Profibus (5 m pump cable incl. - max TMP cable 60 m)	X3501-64000

General Accessories	Part Number
Mains cable NEMA Plug, 3 m long	9699958
Mains cable European Plug, 3 m long	9699957
T-Plus software and serial cable	9699883
Inlet screen ISO 160 and CFF 8"	9699304
Inlet screen CFF 6"	9699302
Water cooling kit (plastic model)	9699347
Water cooling kit (metallic model)	9699337
Water kit, Hose tail 1/8G	9699828
Vibration isolator, ISO 160	9699345
Vibration isolator, CFF 6"	9699334
Vibration isolator, CFF 8"	9699335
Vent flange, NW 10 KF / M8	9699108
Purge valve with KF16-M12 10 SCCM	9699239
Purge valve with 7/16-M12 10 SCCM	9699240
Purge valve KF16-M12 20 SCCM	9699241
Purge valve 7/16-M12 20 SCCM	9699242

Controller Accessories (9699525-9699526)	Part Number
Turbo-V 750/850 TwisTorr Purge/Vent Device N.C. (0.2 m cable)	9696502
Turbo-V 750/850 TwisTorr Fan (0.2 m cable)	9696503
Turbo-V 750/850 TwisTorr Purge/Vent 5 m extension cable	9696504
Turbo-V 750/850 TwisTorr Purge/Vent 15 m extension cable	9696505
Turbo-V 750/850 TwisTorr Purge/Vent 25 m extension cable	9696506
Turbo-V 750/850 TwisTorr Fan 5 m extension cable	9696514
Turbo-V 750/850 TwisTorr Fan 15 m extension cable	9696515
Turbo-V 750/850 TwisTorr Fan 25 m extension cable	9696516
Turbo-V 750/850 TwisTorr 10 m pump extension cable	9696518
Turbo-V 750/850 TwisTorr 20 m pump extension cable	9696519

Controller Accessories (X3501-64000)	Part Number
Air cooling kit (24 V)	X3501-68000
Vent valve extension cable - 5 m	X3501-68004
Turbo-V 750/850 TwisTorr 3 m pump extension cable	9699948
Turbo-V 750/850 TwisTorr 5 m pump extension cable	9699948M001
Turbo-V 750/850 TwisTorr 20 m pump extension cable	9699948M002
Turbo-V 750/850 TwisTorr 30 m pump extension cable	9699948M005
Turbo-V 750/850 TwisTorr 50 m pump extension cable	9699948M006

Turbo Pumps

# AGILENT TURBO PUMP MODELS

## ▶ Agilent Turbo-V 850 TwisTorr System

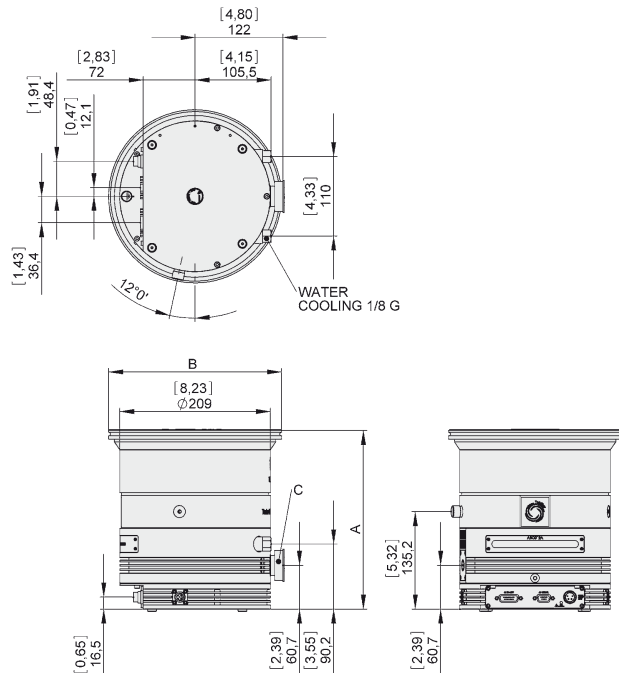

Dimensions: millimeters (inches)

### Technical Specifications

#### Vacuum Performances

Pumping speed for N <sub>2</sub> (*)	N <sub>2</sub> = 750 l/s
Pumping speed for Ar (*)	Ar = 700 l/s
Pumping speed for He (*)	He = 690 l/s
Pumping speed for H <sub>2</sub> (*)	H <sub>2</sub> = 590 l/s
Compression ratio for N <sub>2</sub>	N <sub>2</sub> = 1 x 10 <sup>11</sup>
Compression ratio for Ar	Ar > 1 x 10 <sup>11</sup>
Compression ratio for He	He = 2 x 10 <sup>8</sup>
Compression ratio for H <sub>2</sub>	H <sub>2</sub> = 2.5 x 10 <sup>6</sup>
Base pressure*	<1 x 10 <sup>-10</sup> mbar
<i>(with minimum recommended forepump)</i>	
Max foreline pressure for N <sub>2</sub>	6 mbar
Inlet Flange size	ISO 200K, CFF 10", ISO 200F
Foreline flange	KF25 (ISO 200K, CFF 10") KF40 (ISO 200F)

#### Other

Rotational speed	Selectable from 350 Hz to 825 Hz
Start up time (90% of full speed)	< 3 min
Recommended forepump	PTS300, DS302, IDP-15
Operational position	Any
Cooling options	Forced Air (up to 35 °C ambient temp.) Water (corrosion resistant loop)
Max flange temperature during bake-out (no gas flow)	120°C (CFF), 80°C (ISO)
Noise level (pump at full speed, no load)	FAN off < 52 dB(A) at 1 meter FAN on < 55 dB(A) at 1 meter
Storage temperature	-20 °C to +70 °C
Certifications	CE, C, CSA_US, ROHS compliant
Purge and Vent	Standard Purge & Vent ports Automated Purge/Vent device (accessory)
Weight (with integrated controller)	ISO 200 K = 16.1 kg (35.5 lbs) CFF 10" = 22.6 kg (49.8 lbs)

(\*): According to Pneuop 5608 III, TS 300 PRIMARY PUMP, NO INLET SCREEN

Model	Inlet Flange	A	B	C
9698815	ISO 200K	247.7 (9.75)	Ø 240 (9.45)	KF 25
9698816	CFF 10"	247.7 (9.75)	Ø 253.2 (9.97)	KF 25
9698819	ISO 200F	248.1 (9.77)	Ø 284.86 (11.21)	KF 40

#### Controller Specifications

Controller type	Fully integrated electronics
Motor control mode	Field Oriented Control (FOC)
Input voltage	48 Vdc (± 10%)
Maximum input power	450 W
Maximum output power	400 W (pump ramp-up) 300 W (water cooling) 200 W (forced air cooling)
Input voltage for power supply	100 – 240 Vac (± 10%)
Input frequency for power supply	50 – 60 Hz
Maximum input power for power supply	550 VA
Maximum operating power for power supply	450 W
Interface	Navigator standard remote I/O RS 232, RS 485 serial Can accept Profibus external device
Protection category	IP 54
Data Logger	Standard
Stop speed reading	Standard
Automated Purge/Vent device control	Standard
Leak Detector Mode function	Standard

# TURBO PUMPS

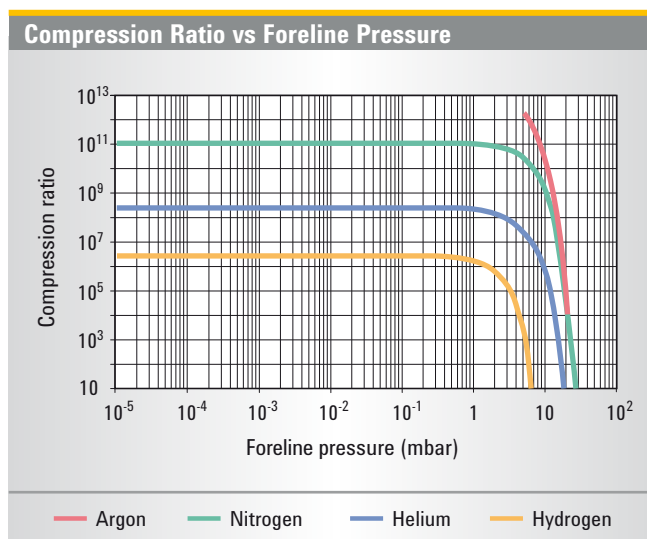
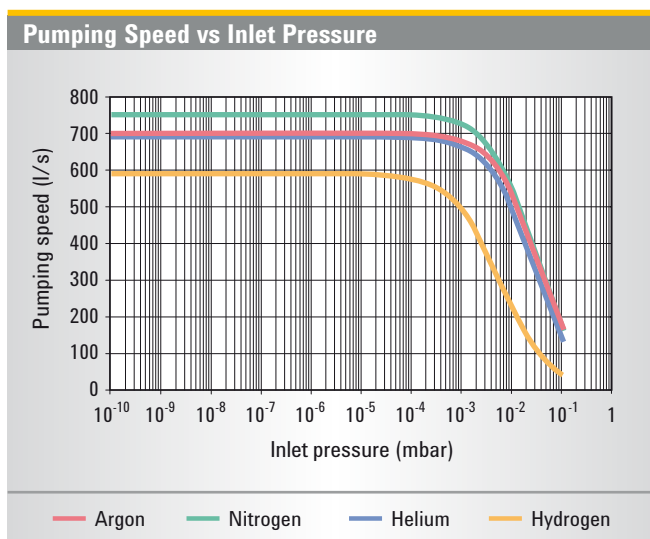

## Ordering Information

Pumping Systems*	Part Number
Agilent Turbo-V 850 ISO 200K On-Board	9698815
Agilent Turbo-V 850 CFF 10" On-Board	9698816
Agilent Turbo-V 850 ISO 200F On-Board	9698819

(\*): Pumping Systems include pump with integrated controller 48 Vdc, inlet screen, 9 and 15 pin mating connectors IP-54.

### Accessories

Turbo-V 750/850 TwisTorr Power Supply (5 m pump cable)*	9696521
Mains cable NEMA Plug, 3 m long	9699958
Mains cable European Plug, 3 m long	9699957
Turbo-V 750/850 TwisTorr Purge/Vent Device N.C. (0.2 m cable)	9696502
Turbo-V 750/850 TwisTorr Fan (0.2 m cable)	9696503
T-Plus software and serial cable	9699883
Inlet screen ISO 200 and CFF 10"	9699316
Water cooling kit (plastic model)	9699347
Water cooling kit (metallic model)	9699337
Water kit, Hose tail 1/8G	9699828
Vibration isolator, ISO 200	9699346
Vibration isolator, CFF 10"	9699336
Vent flange, NW 10 KF / M8	9699108
Purge valve with KF16-M12 10 SCCM	9699239
Purge valve with 7/16-M12 10 SCCM	9699240
Purge valve KF16-M12 20 SCCM	9699241
Purge valve 7/16-M12 20 SCCM	9699242
External Profibus TMP gateway	9699261
Forepump DS 302, with 1 ph., universal motor	9499325
TriScroll Dry Vacuum Pump PTS 300 single phase, US cord	PTS03001UNIV
TriScroll Dry Vacuum Pump PTS 300 single phase, Euro cord	PTS03001UNIVEU
TriScroll Dry Vacuum Pump PTS 300 single phase, UK cord	PTS03001UNIVUK
TriScroll Dry Vacuum Pump PTS 300 3 phase	PTS03003UNIV
IDP-15 Dry Scroll Pump, Std	X3815-64000
IDP-15 Dry Scroll Pump, Std with inlet valve	X3815-64010

(\*) Power Supply is necessary to provide 48 VDC to the on board electronics.



# AGILENT TURBO PUMP MODELS

## ▶ Agilent Turbo-V 850 TwisTorr Rack

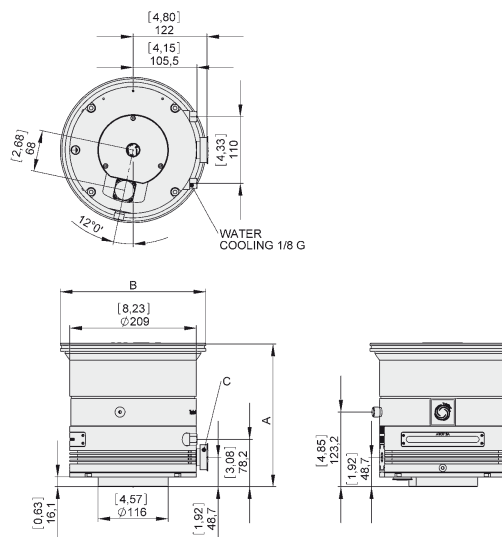

Model	Inlet Flange	A	B	C
9696015	ISO 200K	235.7 (9.28)	Ø 240 (9.45)	KF 25
9696016	CFF 10"	235.7 (9.28)	Ø 253,2 (9.97)	KF 25
9696019	ISO 200F	236.2 (9.30)	Ø 284,86 (11.21)	KF 40

### Technical Specifications

#### Vacuum Performances

Pumping speed for N <sub>2</sub> (*)	N <sub>2</sub> = 750 l/s
Pumping speed for Ar (*)	Ar = 700 l/s
Pumping speed for He (*)	He = 690 l/s
Pumping speed for H <sub>2</sub> (*)	H <sub>2</sub> = 590 l/s
Compression ratio for N <sub>2</sub>	N <sub>2</sub> = 1 x 10 <sup>11</sup>
Compression ratio for Ar	Ar > 1 x 10 <sup>11</sup>
Compression ratio for He	He = 2 x 10 <sup>8</sup>
Compression ratio for H <sub>2</sub>	H <sub>2</sub> = 2.5 x 10 <sup>6</sup>
Base pressure*	<1 x 10 <sup>-10</sup> mbar
<i>(with minimum recommended forepump)</i>	
Max foreline pressure for N <sub>2</sub>	6 mbar
Inlet Flange size	ISO 200K, CFF 10", ISO 200F
Foreline flange	KF25 (ISO 200K, CFF 10") KF40 (ISO 200F)

#### Other

Rotational speed	Selectable from 350 Hz to 825 Hz
Start up time (90% of full speed)	< 6 min (with 5 m pump cable length)
Recommended forepump	PTS300, DS302, IDP-15
Operational position	Any
Cooling options	Forced Air (up to 35 °C ambient temp.) Water (corrosion resistant loop)
Max flange temperature during bake-out (no gas flow)	120 °C (CFF), 80 °C (ISO)
Noise level (pump at full speed, no load)	FAN off < 52 dB(A) at 1 meter FAN on < 55 dB(A) at 1 meter
Storage temperature	-20 °C to +70 °C
Certifications	CE, C, CSA_US, ROHS compliant
Purge and Vent	Standard Purge & Vent ports Automated Purge/Vent device (accessory)
Weight	ISO 200 K = 15.8 kg (34.8 lbs) CFF 10" = 22.4 kg (49.4 lbs)

(\*): According to Pneurop 5608 III, TS 300 PRIMARY PUMP, NO INLET SCREEN

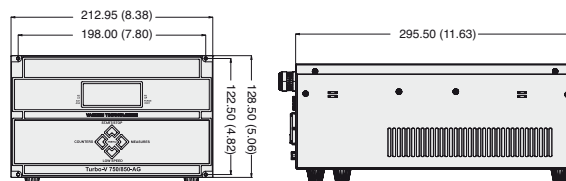

Dimensions: millimeters (inches)

Controller Specifications	Controller Models 9699525-9699526	Controller Model X3501-64000
Input voltage	100 – 240 Vac (± 10%)	100 – 240 Vac (± 10%)
Input frequency	50 – 60 Hz	50 – 60 Hz
Maximum input power	600 VA	800 VA
Maximum output power	320 W (pump ramp-up) 300 W (water cooling) 200 W (forced air cooling)	420 W 300 W 200 W
<i>(Specification with standard cable length 5 mt)</i>		
Interface	Navigator standard remote I/O RS 232, RS 485 serial Can accept Internal Profibus board	Navigator standard remote I/O RS 232
Protection category	IP 20	IP 20
Data Logger	Standard	No
Stop speed reading	Standard	Yes
Active stop	Standard	Yes
Automated Purge/Vent device control	Standard	Yes
External gauge readout	2 ports compatible with Agilent gauges	No
Primary pump control	Pilot 2 external configurable relays (48 Vdc (± 10%) - 250 mA MAX)	Yes

# TURBO PUMPS

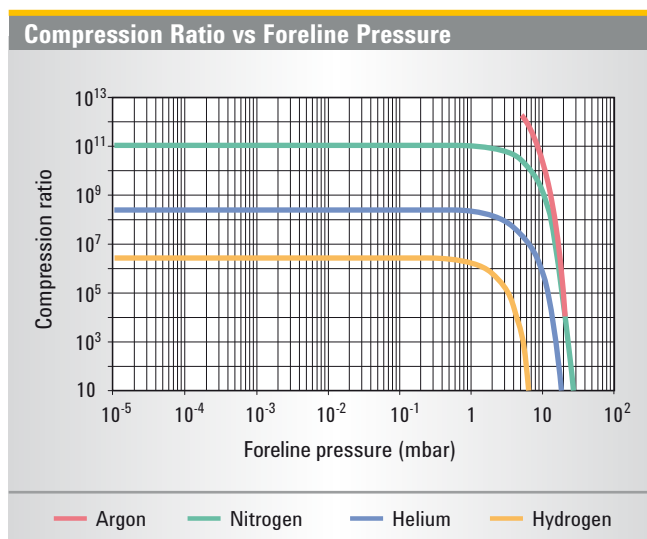
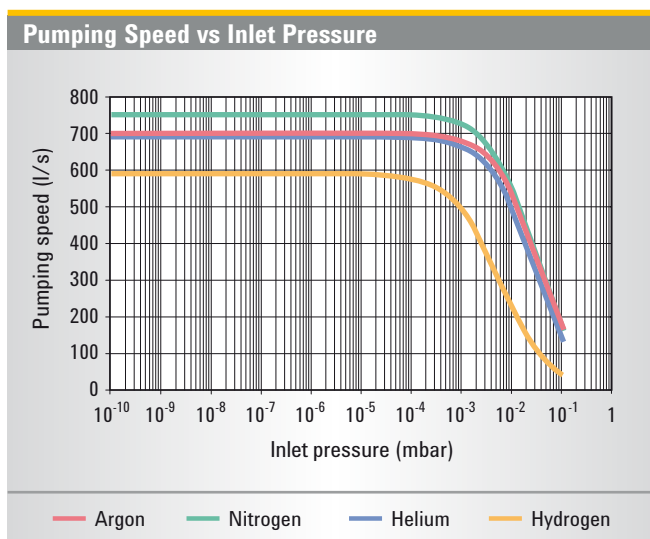

## Ordering Information

Pumps	Part Number
Agilent Turbo-V 850 ISO 200K Rack	9696015
Agilent Turbo-V 850 CFF 10" Rack	9696016
Agilent Turbo-V 850 ISO 200F Rack	9696019

### Controllers

Agilent Turbo-V 750/850-AG Rack CNT (5 m pump cable incl. - max TMP cable 25 m)	9699525
Agilent Turbo-V 750/850-AG Rack CNT Profibus (5 m pump cable incl. - max TMP cable 25 m)	9699526
Agilent Turbo-V 750/850-AG Rack CNT Profibus (5 m pump cable incl. - max TMP cable 60 m)	X3501-64000

### General Accessories

Mains cable NEMA Plug, 3 m long	9699958
Mains cable European Plug, 3 m long	9699957
T-Plus software and serial cable	9699883
Inlet screen ISO 160 and CFF 8"	9699304
Inlet screen CFF 6"	9699302
Water cooling kit (plastic model)	9699347
Water cooling kit (metallic model)	9699337
Water kit, Hose tail 1/8G	9699828
Vibration isolator, ISO 160	9699345
Vibration isolator, CFF 6"	9699334
Vibration isolator, CFF 8"	9699335
Vent flange, NW 10 KF / M8	9699108
Purge valve with KF16-M12 10 SCCM	9699239
Purge valve with 7/16-M12 10 SCCM	9699240
Purge valve KF16-M12 20 SCCM	9699241
Purge valve 7/16-M12 20 SCCM	9699242

Controller Accessories (9699525-9699526)	Part Number
Turbo-V 750/850 TwisTorr Purge/Vent Device N.C. (0.2 m cable)	9696502
Turbo-V 750/850 TwisTorr Fan (0.2 m cable)	9696503
Turbo-V 750/850 TwisTorr Purge/Vent 5 m extension cable	9696504
Turbo-V 750/850 TwisTorr Purge/Vent 15 m extension cable	9696505
Turbo-V 750/850 TwisTorr Purge/Vent 25 m extension cable	9696506
Turbo-V 750/850 TwisTorr Fan 5 m extension cable	9696514
Turbo-V 750/850 TwisTorr Fan 15 m extension cable	9696515
Turbo-V 750/850 TwisTorr Fan 25 m extension cable	9696516
Turbo-V 750/850 TwisTorr 10 m pump extension cable	9696518
Turbo-V 750/850 TwisTorr 20 m pump extension cable	9696519

### Controller Accessories (X3501-64000)

Air cooling kit (24 V)	X3501-68000
Vent valve extension cable - 5 m	X3501-68004
Turbo-V 750/850 TwisTorr 3 m pump extension cable	9699948
Turbo-V 750/850 TwisTorr 5 m pump extension cable	9699948M001
Turbo-V 750/850 TwisTorr 20 m pump extension cable	9699948M002
Turbo-V 750/850 TwisTorr 30 m pump extension cable	9699948M005
Turbo-V 750/850 TwisTorr 50 m pump extension cable	9699948M006

# AGILENT TURBO PUMP MODELS

## ▶ Agilent Turbo-V 1001 Navigator

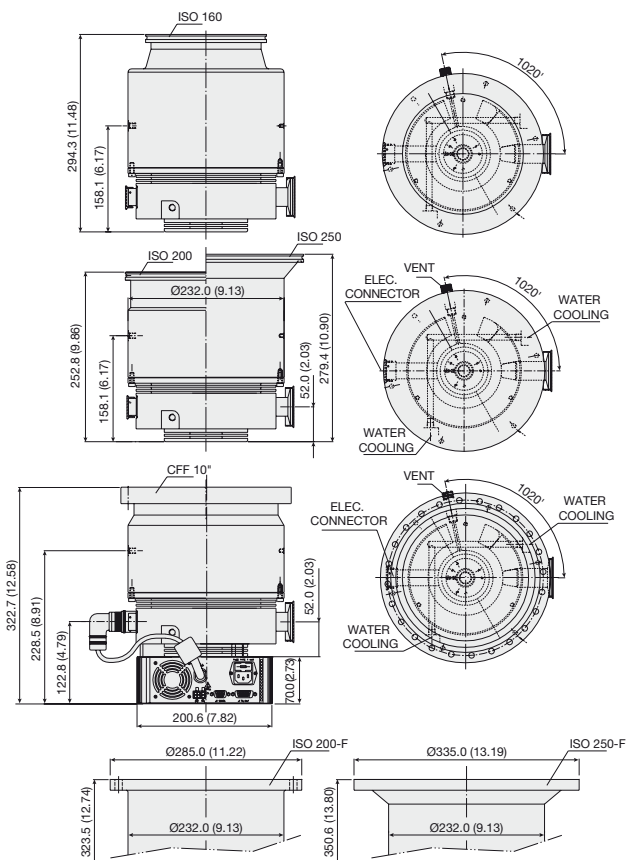

Dimensions: millimeters (inches)

### Technical Specifications

<b>Pumping speed:</b>	ISO 160:	N <sub>2</sub> : 790 l/s	He: 820 l/s	H <sub>2</sub> : 860 l/s
	CFF 10" or ISO 200:	N <sub>2</sub> : 950 l/s	He: 870 l/s	H <sub>2</sub> : 900 l/s
	ISO 250:	N <sub>2</sub> : 1,050 l/s	He: 900 l/s	H <sub>2</sub> : 920 l/s
<b>Compression ratio:</b>	ISO 160	N <sub>2</sub> : 1 x 10 <sup>9</sup>	He: 1 x 10 <sup>7</sup>	H <sub>2</sub> : 1 x 10 <sup>6</sup>
	CFF 10"/ISO 200 - ISO 250	N <sub>2</sub> : 1 x 10 <sup>9</sup>	He: 1 x 10 <sup>7</sup>	H <sub>2</sub> : 1 x 10 <sup>6</sup>
<b>Base pressure*</b> (with recommended forepump)	< 1 x 10 <sup>-10</sup> mbar (< 1 x 10 <sup>-10</sup> Torr)			
<b>Inlet flange</b>	ISO 160	ISO 200	ISO 200-F bolted	CFF 10" ISO 250 ISO 250-F bolted
<b>Foreline flange</b>	KF 40			
<b>Rotational speed</b>	38,000 rpm			
<b>Start-up time</b>	< 4 minutes			
<b>Recommended forepump</b>	Mechanical: Agilent DS 402 Dry scroll: Agilent TS300, IDP-15			
<b>Operating position</b>	Any			
<b>Cooling requirements</b>	Forced air or water			
<b>Bakeout temperature</b>	120 °C at inlet flange max. (CF flange) 80 °C at inlet flange max. (ISO flange)			
<b>Vibration level</b> (displacement)	< 0.01 µm at inlet flange			
<b>Weight kg (lbs):</b>	ISO 160 flange	19 (41.8)		
	ISO 200 flange	19.4 (43.0)		
	CF 10" flange	25.5 (54.2)		
	ISO 250 flange	21.2 (46.6)		
	ISO 200-F and 250-F bolted flange, CF 10" flange	25.5 (54.2)		

\* According to standard DIN 28 428.

**NOTE** • The pump is available with On-board Navigator controller, ½ Rack controller or PCB controller; for information on controllers see also following pages.

SEM version available on request

# TURBO PUMPS

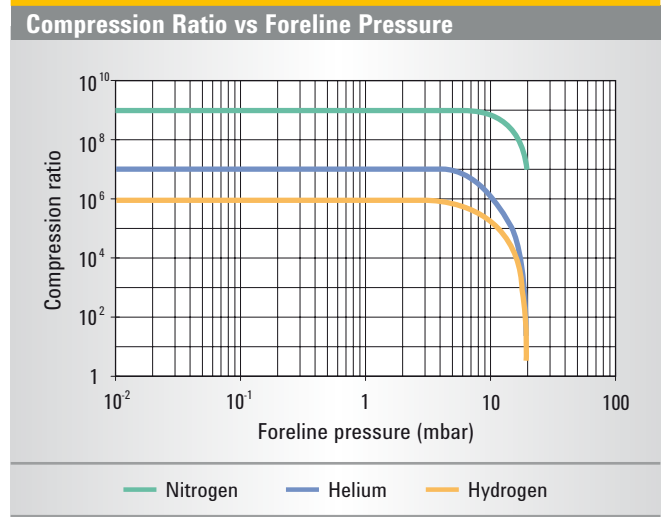
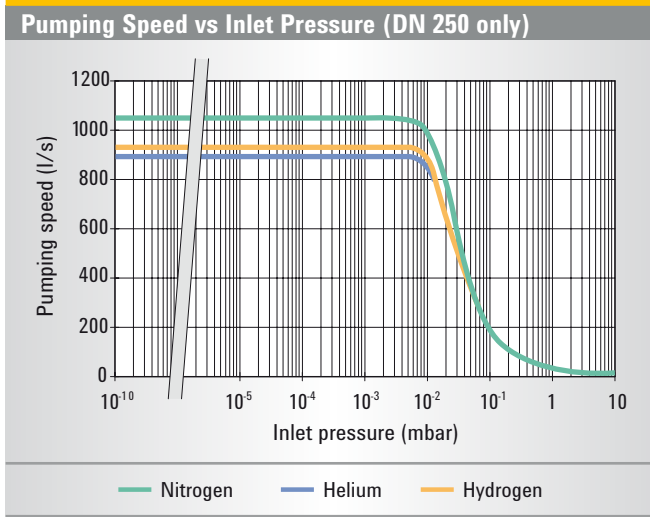

## Ordering Information

Description	Weight kg (lbs)	Part Number
<b>Complete Systems</b>		
Turbo-V 1001 Navigator complete system, ISO 160 flange	24.4 (53.8)	9698840
Turbo-V 1001 Navigator complete system, ISO 200 flange	24.8 (55.0)	9698838
Turbo-V 1001 Navigator complete system, ISO 200-F bolted flange	30.9 (66.2)	9698844
Turbo-V 1001 Navigator complete system, 10" CF flange	30.9 (66.2)	9698839
Turbo-V 1001 Navigator complete system, ISO 250 flange	26.6 (58.6)	9698841
Turbo-V 1001 Navigator complete system, ISO 250-F bolted flange	30.9 (66.2)	9698845
<i>Complete system includes: Pump, Inlet screen, Controller mounted on the bottom, 2 Mains cables (NEMA plug and European plug).</i>		
<b>Pumps</b>		
Turbo-V 1001 Navigator pump, ISO 160 flange	19.0 (41.8)	9698933
Turbo-V 1001 Navigator pump, ISO 200 flange	19.4 (43.0)	9698931
Turbo-V 1001 Navigator pump, ISO 200-F bolted flange	25.5 (54.2)	9698946
Turbo-V 1001 Navigator pump, 10" CF flange	25.5 (54.2)	9698932
Turbo-V 1001 Navigator pump, ISO 250 flange	21.2 (46.6)	9698934
Turbo-V 1001 Navigator pump, ISO 250-F bolted flange	25.5 (54.2)	9698947
<b>Controllers</b> (See following pages for specifications)		
Turbo-V 1001 Navigator controller 120/220 V - 50/60 Hz	5.4 (12.0)	9698978
Turbo-V 1001 Rack controller, 100-240 V	15.7 (35.0)	X3501-64003

Description	Weight kg (lbs)	Part Number
<b>Pump Accessories</b>		
Mains cable NEMA plug, 3 m long		9699958
Mains cable European plug, 3 m long		9699957
Serial cable and T-plus Software <i>(previous release Navigator 2.2 included in the CD)</i>		9699883
Inlet screen DN 160		9699304
Inlet screen DN 200		9699316
Inlet screen DN 250		9699350
Water cooling kit		9699337
Plastic water cooling kit		9699347
Air cooling kit for use with Navigator controller		9699297
Air cooling kit for use with standard rack controller		X3501-68001
Bracket for Navigator controller side routing		9699298
Vibration damper ISO 160	4.0 (9.0)	9699345
Vibration damper, ISO 200	5.0 (10.0)	9699346
Vibration damper, CFF 10"	5.0 (10.0)	9699336
Vent flange, NW 10 KF / M8		9699108
Vent device with adjustable delay time for standard rack controller		9699831
Vent valve for standard rack controller		X3501-68002
Vent valve for Navigator controller		9699834
Purge valve 10 SCCM NW16KF - M12		9699239
Purge valve 10 SCCM ¼ Swagelok - M12		9699240
Purge valve 20 SCCM NW16KF - M12		9699241
Purge valve 20 SCCM ¼ Swagelok - M12		9699242
Purge valve 10 SCCM ¼ Swagelok ¼ Swagelok		9699232
Purge Valve 20 SCCM ¼ Swagelok ¼ Swagelok		9699236

Turbo Pumps



# AGILENT TURBO PUMP CONTROLLERS

## ▶ Agilent Turbo-V 1001 Navigator Controller

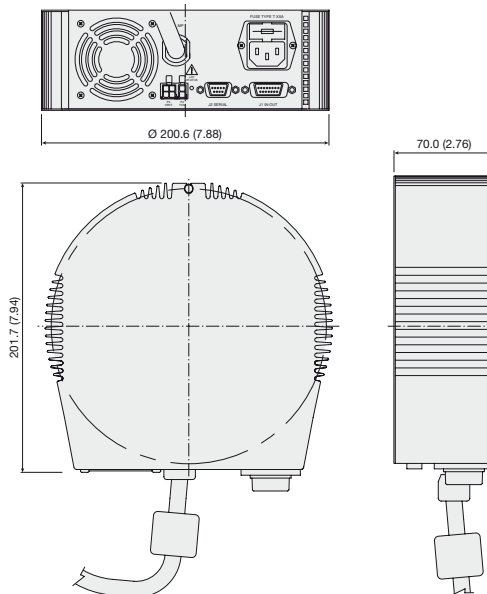

The Turbo-V 1001 Navigator controllers are microprocessor-controlled frequency converters, fully controllable through PC software, with self-diagnostic and protection features that ensure the highest degree of reliability. They can be mounted on board, either on the bottom or on the side of the pump, offering outstanding flexibility and simplicity.

Dimensions: millimeters (inches)

### Technical Specifications

<b>Input voltages</b>	100/120/220/240 VAC
	50/60 Hz, 1 ph
<b>Maximum input power</b>	850 VA
<b>Output voltage</b>	54 VAC, 3 ph
<b>Output frequency</b>	640 Hz
<b>Operating temperature</b>	0 °C to +40 °C
<b>Storage temperature</b>	-20 °C to +70 °C

### Ordering Information

Description	Weight kg (lbs)	Part Number
<b>Controllers</b>		
Turbo-V 1001 Navigator controller 120/220 V - 50/60 Hz	3.0 (6.0)	9698978
<b>Accessories</b>		
Mains cable NEMA plug, 3 m long	0.5 (1.0)	9699958
Mains cable European plug, 3 m long	0.5 (1.0)	9699957
Serial cable and T-plus Software <i>(previous release Navigator 2.2 included in the CD)</i>	0.5 (1.0)	9699883
External "TMP Profibus gateway"	0.4 (0.8)	9699261

# TURBO PUMPS

## ▶ Agilent Turbo-V 1001 Rack Controller

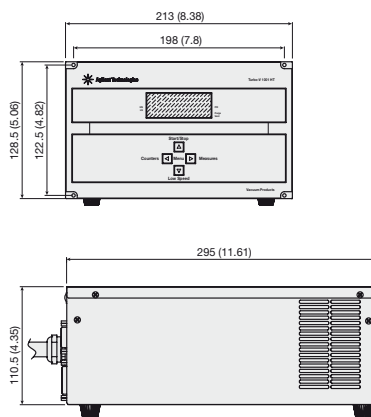

Dimensions: millimeters (inches)

These controllers are microprocessor-controlled frequency converters with self diagnostic and protection features that ensure the highest degree of reliability. The compact, ½ rack unit has a multifunction alphanumeric display for pump status and error code diagnostics. The front panel has a two-line dot matrix LCD display with back lighting. It displays rotational speed as the pump starts up and indicates when full speed is reached. At any time during the operation of the pump, the speed, current, power, and bearing temperature can be displayed. Additionally, the microprocessor acts as a pump

cycle log, and can display the number of vacuum cycles, the cycle time for the current cycle, and the total operating hours on the pump. Remote operation can be accomplished with logic level contact closures and with optional computer interfaces.

PCB controllers are available. Please contact Agilent for details.

### Technical Specifications

<b>Input voltages</b>	100-240 V 1 ph, 50/60 Hz
<b>Maximum input power</b>	800 VA
<b>Output voltage</b>	56 VAC, 3 ph
<b>Output frequency</b>	633 Hz
<b>Maximum output power*</b>	450 W
<b>Startup power</b>	450 W
<b>Operating temperature</b>	+5 °C to +45 °C
<b>Storage temperature</b>	-20 °C to +70 °C

\* Data valid for nitrogen.

### Ordering Information

Description	Weight kg (lbs)	Part Number
<b>Controller</b>		
Turbo-V 1001 Rack controller, 100-240 V	15.7 (35.0)	X3501-64003
<b>Accessories</b>		
Mains cable (European plug, 3 m long)		9699957
Mains cable (American plug, 120 V, 3 m long)		9699958
<b>Options</b>		
Rack adapter for controller	2.0 (4.0)	9699191
Controller to pump extension cable (5 m extension) for Turbo-V 1001	1.0 (2.0)	9699948M001
Controller to pump extension cable (12 m extension) for Turbo-V 1001	2.0 (4.0)	9699951S029
Controller to pump extension cable (20 m extension) for Turbo-V 1001	4.0 (8.0)	9699948M002
External "TMP Profibus gateway"	0.4 (0.8)	9699261

# AGILENT TURBO PUMP MODELS

## ▶ Agilent Turbo-V 2300 TwisTorr Rack

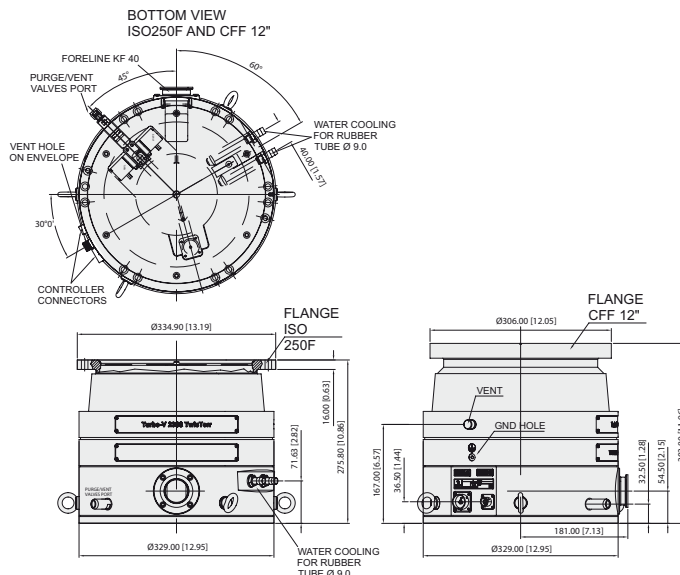

### Technical Specifications

#### Vacuum Performances

Pumping speed for N <sub>2</sub> (*)	2050 l/s
Pumping speed for He (*)	1800 l/s
Pumping speed for H <sub>2</sub> (*)	1500 l/s
Compression ratio for N <sub>2</sub>	>8 x 10 <sup>8</sup>
Compression ratio for He	8 x 10 <sup>5</sup>
Compression ratio for H <sub>2</sub>	4 x 10 <sup>4</sup>
Base pressure* (with recommended forepump)	10 <sup>-10</sup> mbar (7.5 x 10 <sup>-11</sup> Torr) (**)
Max foreline pressure for N <sub>2</sub>	4 mbar
Inlet Flange	ISO 250F, CFF 12" O.D.
Foreline flange	KF 40 NW

#### Other

Nominal rotational speed	33300 rpm
Start-up time without gas load and with the recommended forepump	< 6 minutes
Minimum recommended forepump	TriScroll 600
Operational position	Any
Operating ambient temperature	+5 °C to +35 °C
Bakeout temperature	120 °C (CFF), 80 °C (ISO)
Max rotor temperature	120 °C
Vibration level (displacement)	< 0.01 μm at inlet flange
Lubricant	Permanent lubrication
Cooling requirements	Water
Coolant water	Recommended flow: 200 l/h Temperature: +15 °C to +30 °C Pressure: 3 to 5 bar (45 to 75 psi)
Noise level	<60 dB(A) at 1 meter
Storage temperature	-20 °C to +70 °C
Environment protection	IP54
Weight	ISO 250: 54.2 kg (119.5 lbs) CFF 12": 55.3 kg (121.9 lbs)

(\*): WITHOUT INLET SCREEN

(\*\*): According to standard DIN 28 428, the base pressure is that measured in a leak-free test dome, 48 hours after the completion of test dome bake-out, with a Turbopump fitted with a CFF flange and using the recommended pre-vacuum pump

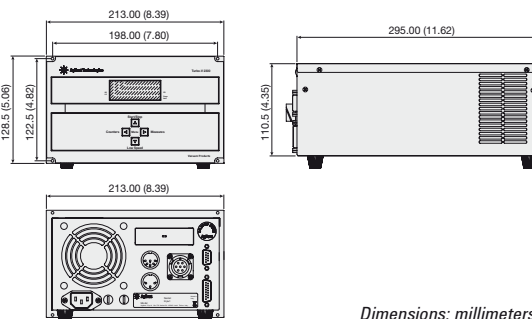

Dimensions: millimeters (inches)

#### Controller Specifications

Input voltages	100-120 VAC, 220-240 Vac, 1-phase
Input frequency	50 - 60 Hz
Maximum input power	1300 VA
Output voltage	64 Vac
Output frequency	555 Hz
Output Power starting	560 W maximum
Output Power normal	450 W maximum
Weight (both models)	12.5 kg (28 lbs)
Installation category	II
Pollution degree	2

# TURBO PUMPS

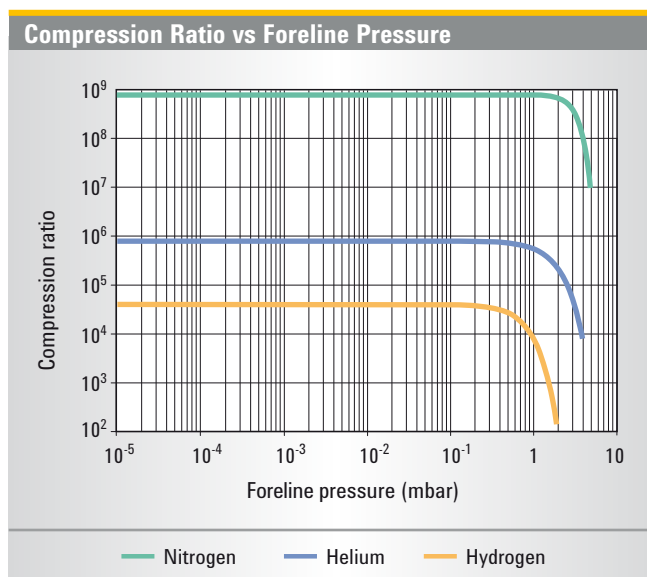
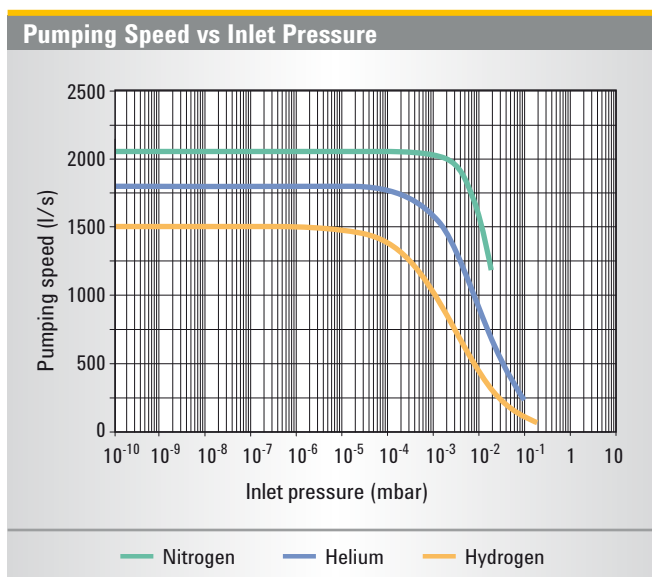

## Ordering Information

Pump	Part Number
Agilent Turbo-V 2300 TwisTorr ISO250F Rack	9696000
Agilent Turbo-V 2300 TwisTorr CFF12" OD Rack	9696001
<b>Controllers*</b>	
Agilent Turbo-V 2300 Rack controller, 100-240 V	X3501-64004
Agilent Turbo-V 2300 Pump-Controller Cable kit, 5 m, for pump and vent valve operation	X3501-68003
(*): Please note that rack controllers do not include the Pump-Controller Cable Kit	
<b>Accessories</b>	
Mains cable NEMA Plug, 3 m long	9699958
Mains cable European Plug, 3 m long	9699957
Center-ring ISO 250	9699144
Inlet screen DIN ISO 250 // CFF12" AISI	9699350
Water cooling kit for 6x8 (IDxOD) flexible tube	9699348
Water cooling kit for 3/8 in. ID flexible tube	9699338

# AGILENT TURBO PUMP MODELS

## ▶ Agilent Turbo-V 1K-G

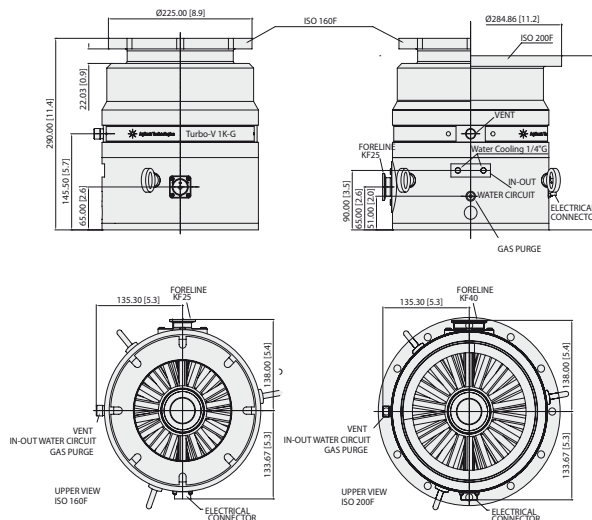

Dimensions: millimeters (inches)

### Turbo-V 1K-G

- Application-specific pumping solution designed for thin film deposition equipment
- High pumping speed and high gas throughput
- Rugged design and highly efficient cooling system for continuous operation
- Gas Purge for bearings protection

### Advanced Electronics

- Rack type or Navigator on board controllers
- Versatile electronics interface with easy to use control Software
- Analog I/O signals and RS232 / RS485 interface as standard Agilent Profibus interface as option

### Technical Specifications

<b>Pumping speed:</b>	ISO 160:	Ar: 750 l/s	N <sub>2</sub> : 810 l/s	He: 950 l/s	H <sub>2</sub> : 680 l/s
	ISO 200:	Ar: 1,040 l/s	N <sub>2</sub> : 1,080 l/s	He: 1,150 l/s	H <sub>2</sub> : 730 l/s
<b>Compression ratio:</b>		Ar: > 5 x 10 <sup>8</sup>	N <sub>2</sub> : > 5 x 10 <sup>7</sup>	He: > 4 x 10 <sup>4</sup>	H <sub>2</sub> : 1.5 x 10 <sup>4</sup>
<b>Base pressure*</b> (with recommended forepump)		< 1 x 10 <sup>-10</sup> mbar			
<b>Inlet flange</b>		ISO 160 F, ISO 200 F			
<b>Foreline flange</b>	ISO 160:	KF 25 NW			
	ISO 200:	KF 40 NW			
<b>Nominal rotational speed</b>		45,500 rpm			
<b>Start-up time</b>		< 5 minutes			
<b>Minimum recommended forepump</b>		> 20 m <sup>3</sup> /h (TriScroll 600, DS 602)			
<b>Operating position</b>		Any			
<b>Operating ambient temperature</b>		+5 °C to +35 °C			
<b>Bakeout temperature</b>		80 °C at inlet flange max. (ISO flange)			
<b>Vibration level</b> (displacement)		< 0.01 μm at inlet flange			
<b>Cooling requirements</b>		Water			
<b>Power supply</b>	Input voltage: 100-240 Vac	Input freq.: 50 - 60 Hz	Max input power: 600 VA	Stand-by power: 30 to 35 W	
	Max operating power: 400 W using Nitrogen and lighter gases (water cooling setting)				
	260 W using Argon (air cooling setting)				
<b>Protection fuse</b> (Navigator controller)		1 x 6.3 A			
<b>Serial communication</b> (Navigator Kit)		RS232 cable with a 9-pin D type male connector and a 9-pin D type female connector, and Navigator software (optional)			
<b>Storage temperature</b>		-20 °C to +70 °C			
<b>Weight</b>		26.8 kg (59.1 lbs)			

\* According to standard DIN 28 428.



# TURBO PUMPS

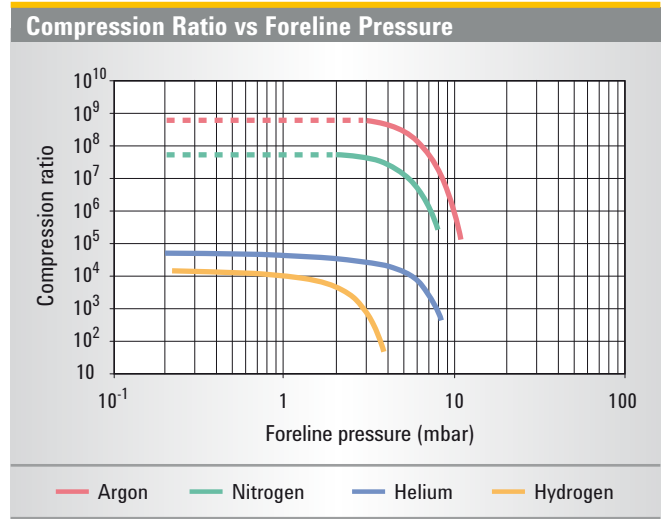
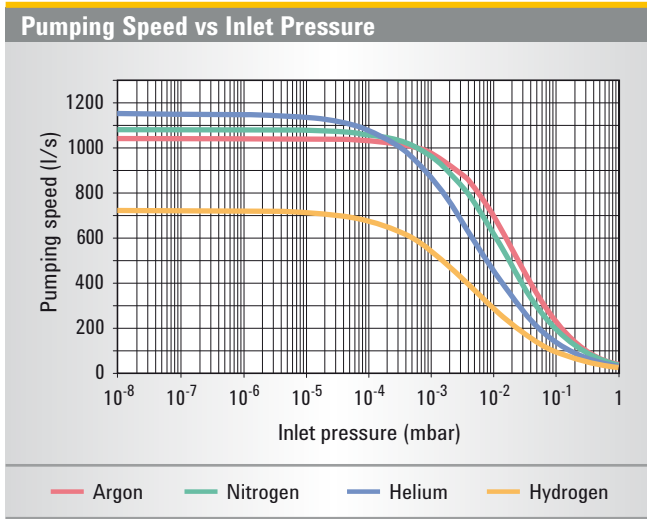

## Ordering Information

Description	Part Number
<b>Pumping Systems</b>	
Turbo-V 1K-G ISO160 F	8698961R002
Turbo-V 1K-G ISO200 F	8698962R001
<b>Controllers</b>	
Turbo-V 1K-G Navigator controller, 120-220 V	9698978M005
Turbo-V 1K-G Rack controller, 100-240 V	X3501-64005
<b>Accessories</b>	
Mains cable NEMA Plug, 3 m long	9699958
Mains cable European Plug, 3 m long	9699957
Serial cable and Navigator Software	9699883
Inlet screen ISO 160	9699304
Inlet screen ISO 200	9699316
Water cooling kit (hose tail G ¼)	9699825
Water cooling kit (Inox G ¼)	9699826
Vent flange, NW 10 KF / M8	9699108
Vent device with adjustable delay time for standard rack controller	9699831
Vent valve for standard rack controller	X3501-68002
Vent valve for Navigator controller	9699834
Purge valve KF16-M12 20 SCCM	9699241
Purge valve 7/16-M12 20 SCCM	9699242
<b>Recommended Forepump</b>	
Rotary Vane pump DS 602, with 1 ph, worldwide motor	9499335
Rotary Vane pump DS 602, with 3 ph, worldwide motor	9499336
Rotary Vane pump HS 452, with 1 ph, worldwide motor	9499360
Rotary Vane pump HS 652, with 1 ph, worldwide motor	9499365
Dry pump TriScroll 600, with 1 ph, worldwide motor	PTS06001UNIV
Dry pump TriScroll 600, with 3 ph, worldwide motor	PTS06003UNIV
Dry pump TriScroll 600 inverter, with 1 ph, worldwide motor	PTS06001INV

# AGILENT TURBO PUMP MODELS

## ▶ Agilent Turbo-V 2K-G System

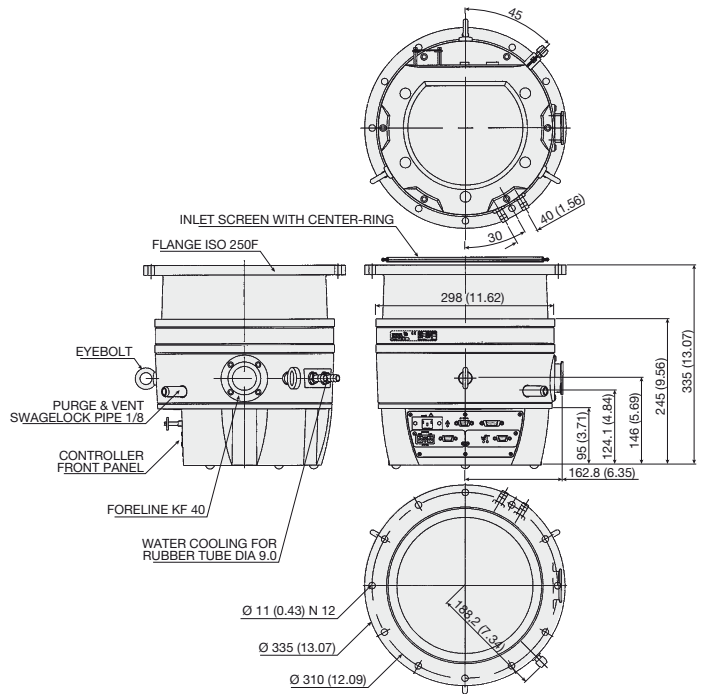

Dimensions: millimeters (inches)

### Turbo-V 2K-G System

- The first application-specific pumping solution designed for thin film deposition equipment
- The highest performing, most compact unit available
- The first fully integrated approach for maximum system productivity and uptime

### The System Interface

- Integrated package includes Turbo Molecular Pump, Drive Electronics, Power Supply, Purge Gas and Communication
- Versatile electronics interface with easy to use control Software
- Analog I/O signals and RS232 / RS485 interface as standard Agilent Profibus interface as option

### Technical Specifications

<b>Pumping speed</b>	N <sub>2</sub> : 1600 l/s	
<b>Compression ratio</b>	N <sub>2</sub> : 3 x 10 <sup>5</sup>	
<b>Base pressure*</b> (with recommended forepump)	< 1 x 10 <sup>-8</sup> mbar	
<b>Inlet flange</b>	ISO 250 F	
<b>Foreline flange</b>	KF 40 NW	
<b>Nominal rotational speed</b>	33,000 rpm	
<b>Start-up time</b>	<7 minutes	
<b>Recommended forepump</b>	> 40 m <sup>3</sup> /h	
<b>Operating position</b>	Any	
<b>Operating ambient temperature</b>	+5 °C to +40 °C	
<b>Power supply</b>	Input voltage	100 - 240 Vac
	Input freq.	50 - 60 Hz
<b>Communication Interface</b>	Analogue I/O	Standard
	RS232 / RS485	Standard
	Profibus	Optional
<b>Dimensions</b>	Height	335 mm (13.18 in.)
	Diameter	335 mm (13.18 in.)
	Weight	35 kg (77 lbs)

\* According to standard DIN 28 428.

# TURBO PUMPS

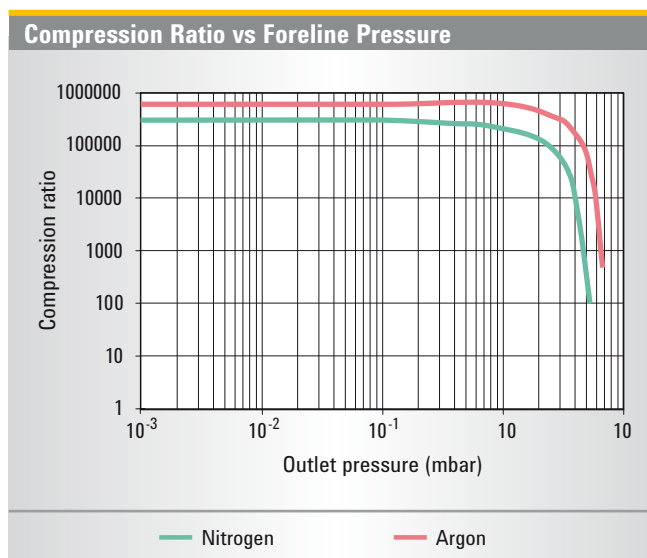
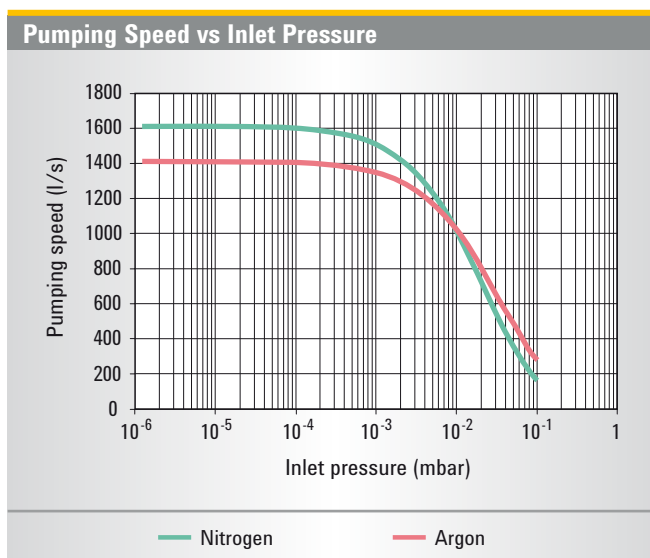

## Ordering Information

Description	Part Number
<b>Pumping Systems (*)</b>	
Turbo-V 2K-G system with MoniTorr	9698871
Turbo-V 2K-G system with Profibus and MoniTorr	9698873
(*) Pumping Systems include Pump with 230 V Integrated Electronics, water hose connection, Inlet Screen with center-ring and pre-installed IP54 Mating Connectors. Both standard models can be equipped with Agilent's MoniTorr device on request. Also 120 Vac units available on request.	
<b>Accessories</b>	
Mains cable NEMA Plug, 3 m long	9699958
Mains cable European Plug, 3 m long	9699957
T-Plus Software and serial cable	9699883
Water cooling kit for 6x8 (IDxOD) flexible tube	9699348
Water cooling kit for 3/8 in.ID flexible tube	9699338
Turbo-V remote cable	9699945
Turbo-V remote panel	9698850
<b>Spare Parts</b>	
IP54 proof mating connectors	9699958
Inlet screen ISO 250 with center ring	9699138
Water hoses	9699825

# AGILENT TURBO PUMP MODELS

## ▶ Agilent Turbo-V 3K-G System

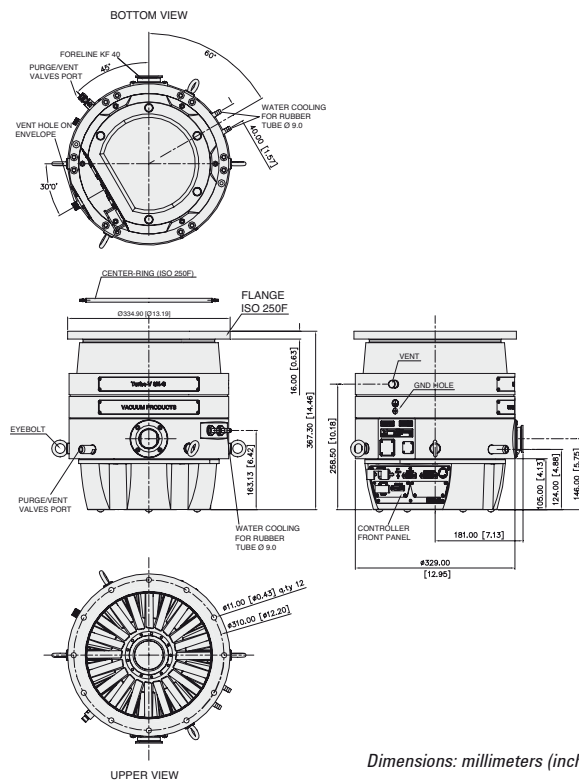

Dimensions: millimeters (inches)

### The Only Truly “Integrated” System in the Market

The Turbo-V 3K-G: an advanced solution for Thin Film applications

- Fully integrated system with on board waterproof power supply
- Vent/purge valves control capability
- Integrated diagnostics
- Multiple interfaced capability
- Lowest power absorption

### Best Footprint to Performance Ratio

- The highest Argon pumping speed (2050 l/s) for its size allows uniform deposition rates at high substrate throughput
- Highest pumping speed in its class: 2200 l/s for Nitrogen
- Throughput: over 1400 sccm for Nitrogen
- The all-turbo, more compact rotor design delivers highest performance with the smallest footprint

### Technical Specifications

<b>Pumping speed</b>	N <sub>2</sub> : 2200 l/s	He: 1900 l/s	Ar: 2050 l/s
<b>Compression ratio</b>	N <sub>2</sub> : > 1 x 10 <sup>7</sup>	He: 6 x 10 <sup>3</sup>	Ar: > 1 x 10 <sup>8</sup>
<b>Base pressure*</b> (with recommended forepump)	<1 x 10 <sup>-8</sup> mbar		
<b>Inlet flange</b>	ISO 250 F		
<b>Foreline flange</b>	KF 40 NW		
<b>Nominal rotational speed</b>	31,800 rpm		
<b>Start-up time without gas load and with the recommended forepump</b>	< 6 minutes		
<b>Foreline pressure</b>	< 0.5 mbar		
<b>Minimum recommended forepump</b>	> 60 m <sup>3</sup> /h (depending on gasflow requirements)		
<b>Operating position</b>	Any		
<b>Cooling requirements</b>	Water		
<b>Weight (ISO 250)</b>	52 kg (114.63 lbs)		

\* According to standard DIN 28 428.

# TURBO PUMPS

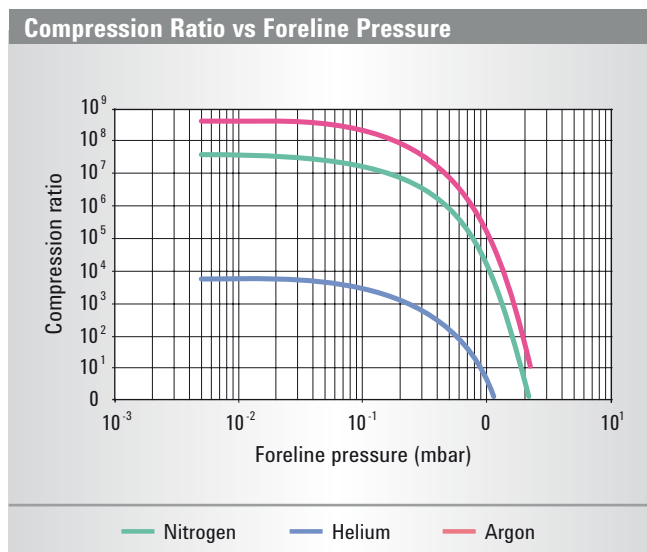
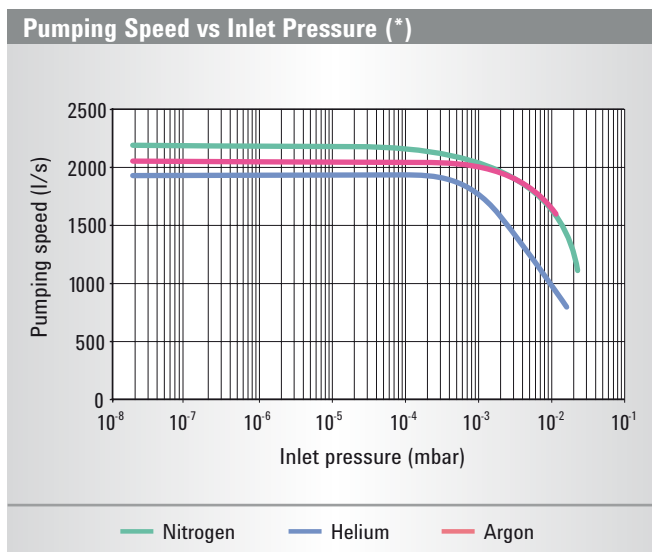

(\*) Measured with a 60 m<sup>3</sup>/h forepump.

## Ordering Information

Description	Part Number
<b>Pumping Systems (*)</b>	
Turbo-V 3K-G ISO 250 F System with integrated purge/vent device	9698888
Turbo-V 3K-G ISO 250 F System with Profibus and integrated purge/vent device	9698889
(*) Pumping Systems include Pump with 230 V Integrated Electronics, Inlet Screen installed on the pump, separate center-ring and pre-installed IP54 Mating Connectors. Both standard models can be equipped with Agilent's MoniTorr device on request. Also 120 Vac units available on request.	
<b>Accessories</b>	
Mains cable NEMA Plug, 3 m long	9699958
Mains cable European Plug, 3 m long	9699957
T-Plus Software and serial cable	9699883
Water cooling kit for 6x8 (IDxOD) flexible tube	9699348
Water cooling kit for 3/8 in.ID flexible tube	9699338
<b>Spare Parts</b>	
IP54 proof mating connectors	9699960
Inlet screen ISO 250	9699350
O-ring and center ring ISO250	9699144



# AGILENT TURBO PUMP ACCESSORIES

## Inlet Screens

To prevent any possible damage to the pump blades caused by particles falling into the pump, an inlet screen is available as an accessory. The inlet screen is a curved stainless steel mesh. It provides protection against debris larger than 0.7 to 3 mm (depending on the model), while reducing the pumping speed by only about 10%.

For ordering information, see individual pumps.

## Air Cooling Kits

A fan is provided as an option for applications requiring forced air flow. The fan is easily installed using the included installation kit.

The air cooling kit for the Turbo-V 81's can be mounted beside or underneath the pump body. The fans for all the other pump models can be installed in a side location only. The maximum allowable ambient temperature for an effective cooling action is 30 °C. To meet the air flow rate specifications, care must be taken not to restrict or cover the space around the fan so that air can flow freely. The operation of the cooling fan is controlled by the Turbo controller.

For ordering information, see individual controllers.

## Water Cooling Kits

A water cooling kit is provided to cool the pump when operating at high inlet or high exhaust pressures. The cooling water can be supplied by an open circuit with drainage or a closed-loop refrigerated system.

Care must be taken to secure the tubes to ensure that they do not detach during operation. Four different kits with various tube sizes are available (refer to the following table).

Tube Size	Material	Screw Thread	Part Number
4 x 6 mm (ID x OD)	Plastic	1/8 BSP	9699347
6 x 8 mm (ID x OD)	Plastic	1/4 BSP	9699348
1/4" ID	SST	1/8 BSP	9699337
3/8" ID	SST	1/4 BSP	9699338

For ordering information, see individual pumps.

## Vibration Dampers

Highly sensitive equipment such as an electron microscope and certain analytical instruments require extremely low vibration amplitudes. The dampers reduce turbopump vibration

amplitude by at least a factor of 10 at their main frequencies. They are available up to a size of 200 mm (ISO 200 or CFF 10" O.D.). To effectively decouple the equipment from the pump, the vibration damper must be installed between the connecting flanges.

For ordering information, see individual pumps.

	H (mm)	H (inches)
Vibration Damper 4 1/2" CF	96.5	3.80
Vibration Damper 6" CF	101	3.97
Vibration Damper 8" CF	110	4.33
Vibration Damper 10" CF	113	4.45
Vibration Damper 63 ISO	84	3.31
Vibration Damper 100 ISO	84	3.31
Vibration Damper 160 ISO	88	3.46
Vibration Damper 200 ISO	88	3.46

## Turbo Vent Valve

The Turbo Vent Valve, consisting of a control unit and a valve, is a complete unit for automatic venting of the Turbo pump when it is switched off or during a power failure. The valve is a normally open, electromagnetically-actuated valve with a filter on the air inlet. The control unit is powered by the Turbo controller and is provided with a fixed delay time of about 5 seconds to avoid undesired venting during a temporary power failure and to allow closure of the system valves before venting.

For ordering information, see individual controllers.

## Turbo Vent Device

To control the venting of the Turbo pumps when they are switched off or during a power failure, a vent device is offered. The Turbo vent device consists of a normally closed valve and a control unit. The valve is electromagnetically-actuated and has a filter on the air-inlet. The control unit is powered by the Turbo controller and has a built-in battery backup. Delay and venting times are adjustable up to 36 minutes to optimize the venting conditions for each application.

For ordering information, see individual controllers.

## Handheld Terminal

The handheld terminal is a remote control display for use with V 81 series Turbo pumps when connected to a controller without a front panel. It consists of an LCD alphanumeric display and keyboard which provide useful real time indications of the operating conditions and parameters of the turbopump.

Moreover, it allows the reprogramming of the controller parameters and troubleshooting of the pump and controller. The handheld terminal is connected to and powered from the Turbo-V controller through a 1.5 meter cable.

For ordering information, please call your local Agilent Office.

## Purge Valve

To protect the bearings of a turbomolecular pump used with aggressive process gases, a measured supply of inert gas (N<sub>2</sub>, Ar) must flow into the pump body around the upper bearing toward the fore-vacuum line. The Agilent fixed orifice purge valve is calibrated for nitrogen to provide the correct gas flow to safely operate Turbo pumps. For ordering information, see individual pumps.

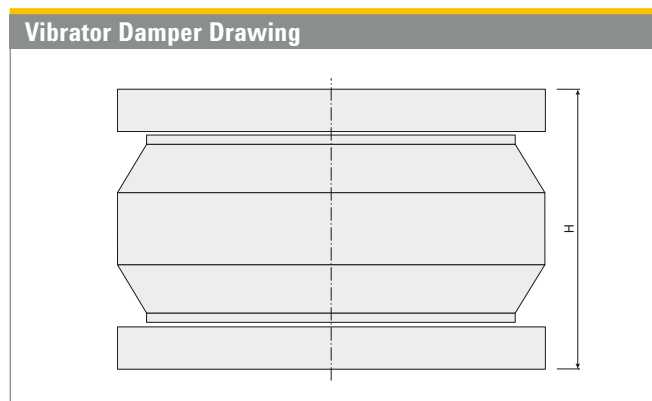

### Vibration Level

Thanks to low vibration, focused design, and computer assisted balancing tools, today turbomolecular pumps generate very low levels of mechanical vibration. This is mainly a result of the numerical modeling of the pump rotodynamics (see Figure 1) and a specific vibration damping system already built into the pump structure. Thanks to both design features, today ceramic ball bearings pumps are standard even in very high vibration applications like SEM and Metrology Tools.

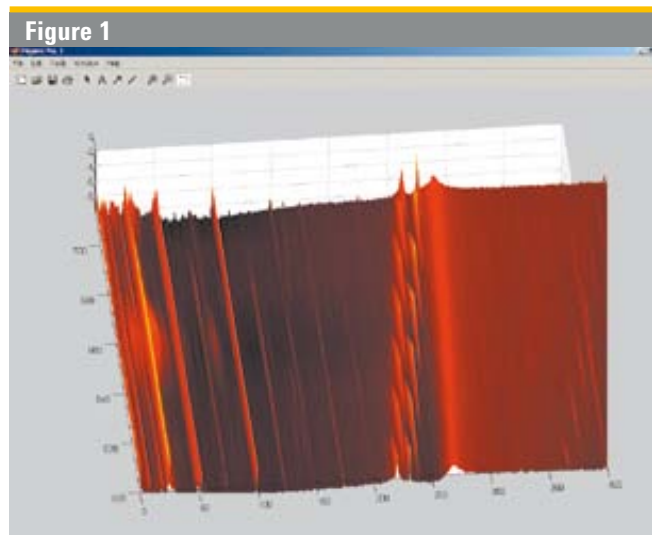

Figure 1: A typical vibration spectrum of a turbomolecular pump can be seen in Figure 2:

Possible sources of vibration in a turbomolecular pump are unbalanced rotor, high frequency motor or bearings. Rotor unbalance can be reduced to a very low level through dynamic balancing, which minimizes forces caused by a nonsymmetric distribution of masses in relation to the rotational axis. As an order of magnitude, the radial displacement on the pump HV flange after balancing can be as low as 0.001  $\mu\text{m}$ .

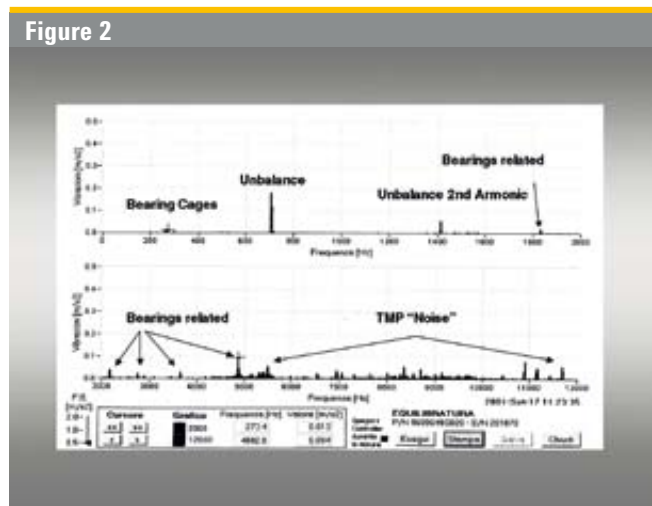

Figure 2: Possible sources of vibration in a turbomolecular pump are unbalanced rotor, high frequency motor or bearings.

The vibrations from a high frequency motor are caused by electromagnetic interactions between the motor stator and rotor: their characteristic frequencies are multiples of the motor driving frequency. Also, the rotor supports generate both white noise and vibrations at specific frequencies of the bearings' moving parts (cage, balls and rotating ring, usually the inner one).

In general, the vibrations caused by an electric motor or bearing are even lower than those caused by unbalance. They may be relevant in the case of bearing damage or because of excitation of a natural resonant frequency of the system connected to the pump. In the second case, the system structure should be modified by adding mass, changing the stiffness and/or inserting a vibration damper between pump and system.

### Operation in Presence of Magnetic Fields

Magnetic fields induce eddy currents in the turbomolecular pump rotor that tend to oppose its rotation. As a consequence the power delivered to the electrical motor is increased.

Since the pump rotor is not in contact with the stator, all the heat generated by the eddy currents must be dissipated by radiation, so the rotor can be overheated even if the static parts remain cool.

According to our tests, the maximum magnetic field that our pumps can tolerate is:

- 50 Gauss in the transversal direction
- 100 Gauss in the axial direction

In these cases, a power increase to the motor can be expected.

If the magnetic field is greater than the above values a shield must be used in order to have a residual magnetic field around the pump below the value specified.

Please contact Agilent for more details.

### Turbomolecular Pump Bearings and Lubrication System

The Turbo-V pumps incorporate Agilent's innovative ceramic bearing design with a proprietary ultra-low vapor pressure solid lubricant, which enables these pumps to provide a long service life and a high degree of cleanliness under most operating conditions. This lubrication system is a superior feature of Agilent Technology and guarantees no contamination of the vacuum system, especially when compared to other oil-lubricated turbomolecular pumps (See figures 3-4).

The ceramic bearings utilize balls made of silicon nitride, a polycrystalline material with an amorphous intergranular binder base that offers the following advantages:

#### Hardness

This is a critical aspect of bearing design, and it closely relates to bearing performance and reliability. The silicon nitride material used in Agilent's Turbo-V bearing system is twice as hard as conventional steel providing dramatic improvement in wear resistance while minimizing the effects of surface contact and stress.

# AGILENT TURBO PUMP TECHNICAL NOTES

Figure 3 - Typical Competitor Pump

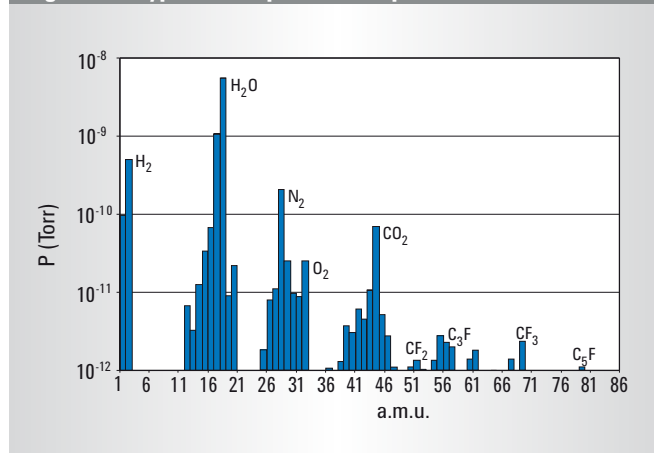
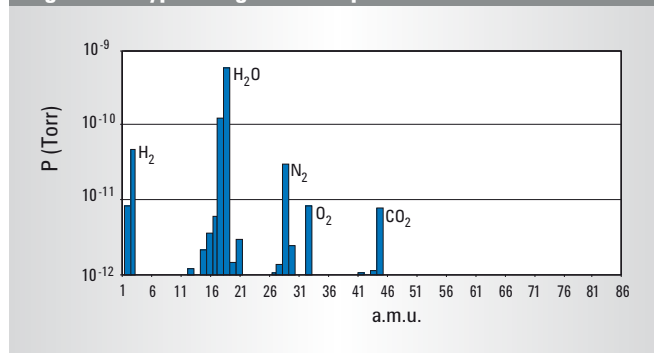

Figure 4 - Typical Agilent Pump



## Weight

Silicon nitride is 40% less dense than conventional steels, which helps to reduce centrifugal loading and stress levels at high rotational speeds, especially in the bearing race area.

## Friction

Silicon nitride's low coefficient of friction enhances wear resistance and adds to the bearing's operational life.

## Thermal Stability

With its low thermal expansion coefficient, the silicon nitride bearing material ensures that tight tolerances and mating component fit will be maintained over an extremely wide temperature range. In addition, silicon nitride has an outstanding resistance to fracture by thermal shock.

## Chemical Stability

Silicon nitride is virtually inert.

Another feature of the Turbo-V bearing system is its proprietary lubricant which has an extremely low vapor pressure and is virtually hydrocarbon free. The use of this lubricant in the permanently sealed bearing system ensures clean, reliable operation without the need for any maintenance whatsoever.

## Agilent T-plus

Agilent T-plus (Turbo Pumps Linked User Software) is the new communication, control and monitoring software for Agilent Turbomolecular Pumps and all other Agilent products featuring the Agilent Window Serial Protocol.

With T-plus, you can simultaneously drive and control one or more Turbo Pumps, connected to a PC through an RS232 or an RS485 serial communication.

Automatic identification of the connected Pumps, description of each command always on screen, and User Interface adaptable to the Pump Status are only some of the new features developed to make the approach to pump settings easy and to reduce the number of steps during pump configuration.

Moreover, special care is given to the GUI (Graphical User Interface), to reproduce the environment of well-known User Interfaces (such as Microsoft Windows applications), to obtain a real User Friendly tool, and to reduce the user learning time.

T-plus software features several options like Data Logging, Chart Representation and Network Configuration, to help you configure your Vacuum devices quickly, and to check your vacuum system status at any time.

Exhaustive online Help is also included, providing the user with a complete, easy to learn system, tailored to customer requirements.

*The previous software release Navigator 2.2 is included in the T-plus CD.*

Figure 5

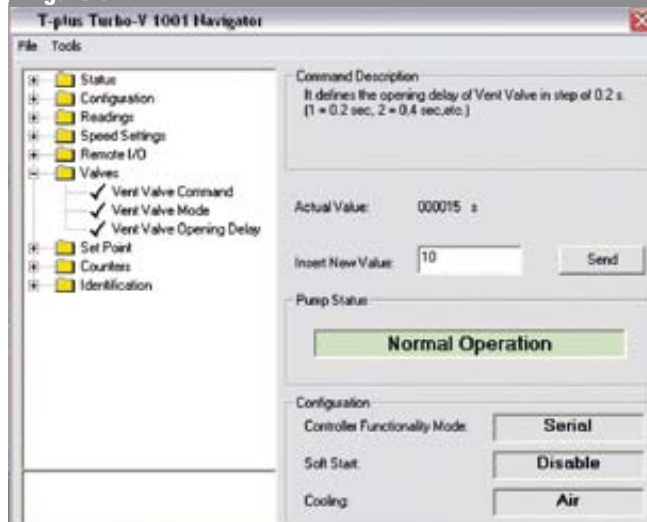

## CE/CSA, EMC Electrical Specifications Compliance

Compliance to these norms guarantees that there are no limits on the use of the controllers and turbopumps in every type of ambient, and that their use doesn't create any kind of disturbance to electronic units connected to the same line.

Agilent's new generation of Turbo controllers comply with the limits given by the following norms:

EN 55011 Class A group 1

EN 61000/3/2

EN 61000/3/3

EN 61000/4/2

EN 61000/4/3

EN 61000/4/4

EN 61010-1

UNI EN 291-1

UNI EN 292-2

EN 1012-2

# AGILENT TURBO PUMP SERVICE AND SUPPORT PLANS

Agilent Vacuum Products offers one of the most comprehensive service and support plans in the industry. As a worldwide, first class company we strive to offer added value to our Customers wherever they may be located. Excellence in Service and Support is a key factor in added value. Support can be accomplished with qualified Engineers and an appropriate logistic infrastructure.

Technical skills and infrastructure are two areas where we are continuously making medium and long-term investments. Our daily customer support philosophy is focused on two important factors: fast response and no hassle.

This philosophy translates to the following sections of our Turbo Pump Service and Support Plan:

- **Worldwide Parts Sourcing Plan:**  
Three Progressive Levels of Support
- **Technical Assistance:** Customer Support, Application Support, Application Training

Agilent Vacuum **Products is committed** to providing our Customers with the most comprehensive service plans possible.

The following pages detail the standard sections of our Turbo Pump Service and Support Plan. For more information, or if you have a need for customized solutions, please contact your Agilent representative.

Often, excellent products are not enough: Agilent's constant presence with Customer Service as a responsive partner is what really makes a difference.

## Worldwide Parts Sourcing Plan

- **Repair Program**  
Agilent products offer unmatched reliability, performance and cleanliness. Production requirements, however, inevitably create, over time, the need for maintenance and repair. Timely repair at Agilent will keep your products performing at an outstanding level all the time.

- **Advanced Exchange Program**  
To maximize uptime, and for those occasions where time is essential, Agilent offers exchange units for advance shipment.  
Exchange units are fully remanufactured to the same strict standards as new products. They are kept in stock in North America, Europe, China, Japan, Korea, Singapore, Taiwan and India.  
As soon as requested, your Exchange unit can be shipped for overnight delivery. This efficiency is due to our logistic infrastructure and is the result of excellent teamwork among our Service and Customer Service Teams!  
The Exchange and Repair Programs are available worldwide and allow global OEMs and End-Users consistent delivery time, value pricing, consistent part numbers, and simple order processing procedures.
- **Upgrade Program**  
The Upgrade Program is designed for customers who need to replace an Agilent (formerly Varian) product at the end of its life, or of old technology, with a newest technology product. For example, a customer may wish to replace a Turbo-V250 with our Turbo-V301 Navigator.

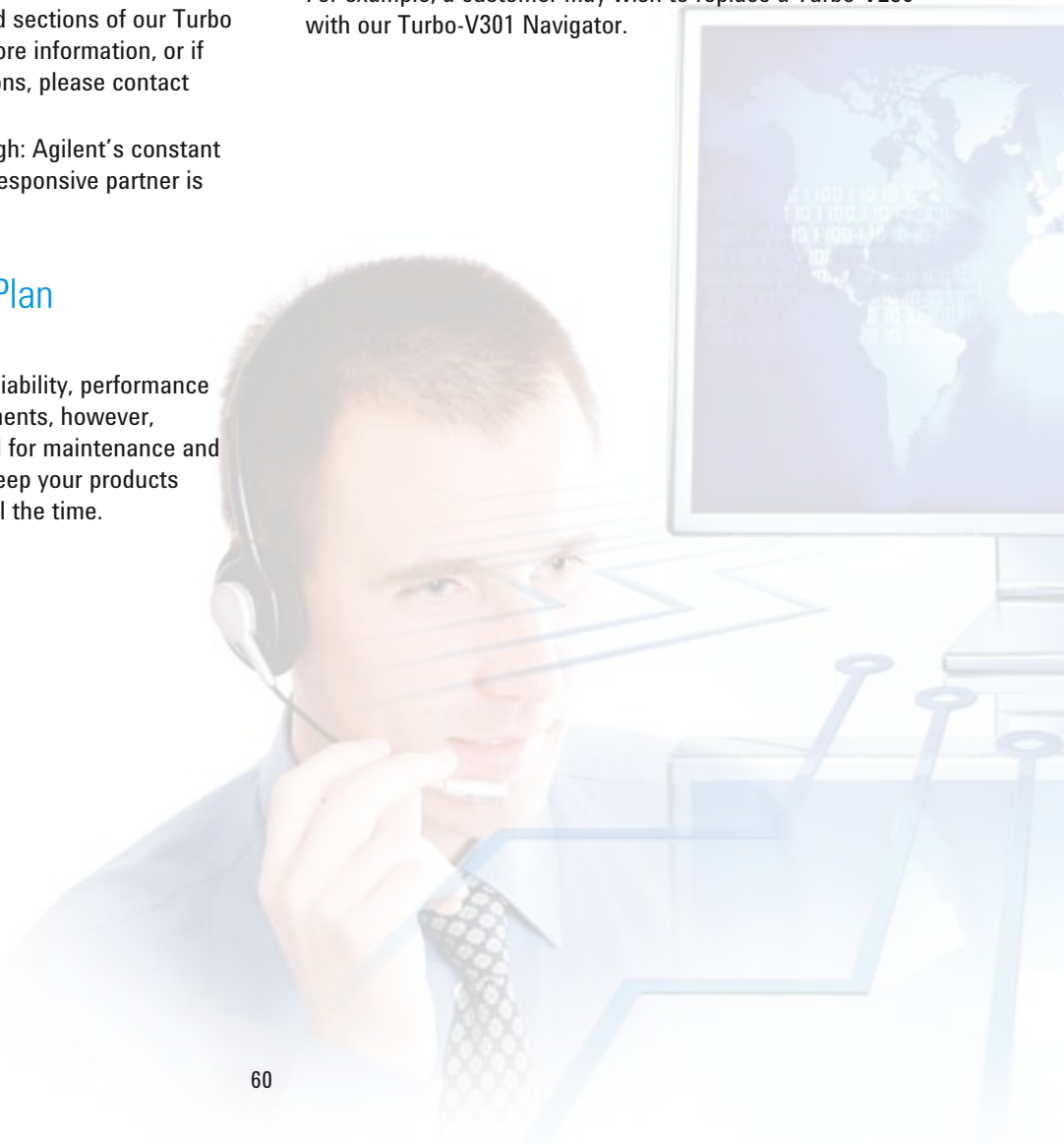



# TURBO PUMPS

The Upgrade Program includes proactive technical installation support, by telephone and full 12-month warranty.

Agilent's Turbo pump Upgrade Program provides a customer with the same outstanding support delivered with our service programs, including:

- RMA# tracking
  - Replacement with remanufactured pump of the newest technology
  - Advance replacement
  - 24-hour expedited order management
  - WEB on-line order status & shipment tracking
- **End User Extended Warranty**

The End User Extended Warranty is a Service Agreement that provides coverage extension beyond the standard 12 months warranty of a product. It extends for additional 12 months the coverage from failures due to defects in material and workmanship.

By extending the warranty of purchased products, post-sales satisfaction is guaranteed. This is the result of the relevant cost decrease while cost predictability is increased.

The End User Extended Warranty has been designed to cover the needs of the End User Market:

- General Purpose Vacuum applications.
- High Energy Physics Ultra High Vacuum applications.

## Ordering Information for End User Extended Warranty

General Purpose Vacuum Applications	Part Number
Extd. Warranty 12M Turbo 80 l/s class	EW81
Extd. Warranty 12M Turbo 300 l/s class	EW300
Extd. Warranty 12M Turbo 700 l/s class	EW700
Extd. Warranty 12M Turbo 1000 l/s class	EW1000
Extd. Warranty 12M Turbo TV1KG	EWTV1KG
Extd. Warranty 12M Turbo TV2KG	EWTV2KG
Extd. Warranty 12M Turbo TV3KG	EWTV3KG
Extd. Warranty 12M Turbo (other config.)	EW969TMP
High Energy Physics UHV Applications	Part Number
Extd. Warranty HEP 12M Turbo 80 l/s class	EW969TV81
Extd. Warranty HEP 12M Turbo 300 l/s class	EW969TV301
Extd. Warranty HEP 12M Turbo 700 l/s class	EW969TV701
Extd. Warranty HEP 12M Turbo 1000 l/s class	EW969TV1001
Extd. Warranty HEP 12M Turbo V2300	EW969TV2300
Extd. Warranty 12M Turbo (other config.)	EW969TMP

- **Cleaning Service**

Agilent offers a cleaning service in cases where a turbo pump may have been exposed to chemically hazardous materials.

This service is available worldwide and allows global OEMs and End-Users consistent delivery time, pricing, part numbers, and order processing procedures.

Ordering Information for Agilent's Cleaning Service

Turbo-V Pump Size	Part Number
From V 60 to TwisTorr 304 FS	TURBOCLEAN1
From V 450 to V 701 Navigator	TURBOCLEAN2
From V 1000 to 3K-G / 2300 TwisTorr	TURBOCLEAN3

# AGILENT TURBO PUMP SERVICE AND SUPPORT PLANS

## Technical Assistance

As an Agilent Customer, you can rely on an attentive and professional support staff, dedicated to providing you with the easiest and most personalized service solution possible.

### Customer Support

- Our toll-free lines, with mother tongue Technical Support Engineers at worldwide locations, allow us to provide you with quick responses to your needs.
- All issues are entered into our data-base, and become available to all Agilent's Technical Support Centers and to our R&D Departments for possible product improvements.

### Americas

North America: Toll-Free +1 800-882-7426  
Fax +1 781-860-5437

Central and South America: Tel. +1 781-861-7200  
Fax +1 781-860-5437

### Asia

Japan: Toll-Free +81 120-477-111  
Fax +81 120-880-598

Korea: Toll-Free 080-222-2452  
Fax +82 (0) 2-3452-3947

China: Beijing Office Toll-Free 800-820-3278  
Fax +86 (0)10-6439-2765  
Shanghai Office Toll-Free 800-820-3278  
Fax +86 (0)21-6628-5169  
Guangzhou Office Toll-Free 800-820-3278  
Fax +86 (0)20-8669-5861  
Shenzhen Office Toll-Free 800-820-3278  
Fax +86 (0)755-8276-3181

Taiwan: Toll-Free 0800-018-768

Singapore: Toll-Free 1800-276-2622

Malaysia: Toll-Free 1800-880-805

India Toll-Free 1800-1801-517

### Europe and Israel

Austria, Belgium, Finland, France, Germany, Holland, Ireland, Israel (\*), Italy, Portugal, Spain, Switzerland, UK:

Toll-Free 00-800-234-234-00

Toll-Free-Fax 00-800-345-345-00

(\* ) From Israel dial 012 instead of initial 00

### Other Countries

Tel. +39 011-9979-369

Fax +39 011-9979-330



### Application Support - Application Training

- Our Application Engineers can bring Agilent's expertise in vacuum technology to our customers
- Application Support is a project-based activity where our experts assist you solving the application issues that might arise pre-sales or post-sales
- By designing solutions that meet customer needs, Agilent aims at creating a positive and synergetic relationship with customers
- Our experts keep you up-to-date on industrial and scientific vacuum applications with the goal of optimizing the use of our products on your system